

MINI-CAT® Users Manual

Component Video / VGA Over UTP

Video Transmission Systems



Manual #: UMA1074 Rev. 6

HR HALL
RESEARCH

Hall Research, Inc
1163 Warner Ave. Tustin, CA 92780

Table of Contents

1.0	GENERAL DESCRIPTION	2
1.1	NOTE FOR –CV MODELS	2
2.0	FEATURES.....	3
3.0	SETUP AND OPERATION	3
3.1	IMPORTANT NOTE REGARDING SELECTING THE UTP CABLE.....	6
3.2	DIP SWITCH SETTINGS FOR THE MODEL UV1-SL.....	7
4.0	SPECIFICATIONS.....	8

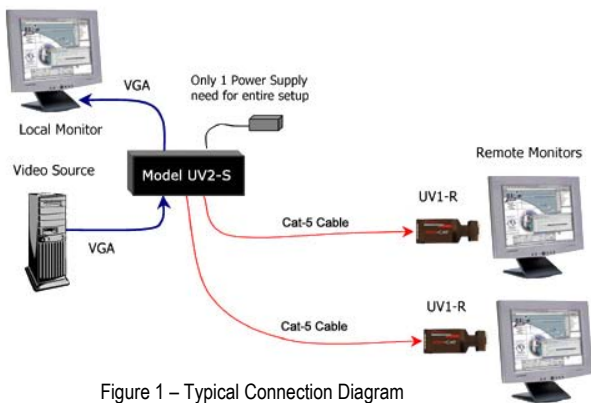

Figure 1 – Typical Connection Diagram

1.0 General Description

This User's Manual covers the *Mini-Cat*® series of high-resolution PC or HDTV component video transmission system.

The transmission systems are comprised of one Sender unit and one or more Receiver units. They enable you to split and extend a PC VGA video or analog Component HDTV signal to 500 feet.

A unique feature of the system is that in most installations only one power supply is enough to power the sender and the receiver(s).

All sender units can supply power to all the receivers connected to them via the Cat5 cable. If the cable is longer than 330 feet or 100 m then the receiver may require a separate supply. Conversely, in the case of 1-to-1 setups, the Receiver unit can also supply power to the Sender (only when the Sender is a single channel).

The characteristics of the Sender units are summarized below:

Feature	UV1-S	UV1-S-WP	UV1-SL	UV2-S	UV4-S	UV8-S
Local VGA Loop out	No	No	Yes	Yes	Yes	Yes
# of RJ45 Outputs	1	1	1	2	4	8
Sends Power over UTP	Yes	Yes	Yes	Yes	Yes	Yes
Mounts on Wall	No	Yes	No	No	No	No

Table 1 – Sender Characteristics

Note: For Cat-5 runs of over 330 feet, the receivers may need their own additional supplies sold separately (HRT model # 511-GS569).

1.1 Note for –CV models:

The *Mini-Cat*® series senders can be built to extend Composite Video and Stereo Audio up to 2000 feet, and are sold with HD15 to 3 RCA A/V cables. These models are labeled with –CV (e.g.: UV2-S-CV) and are *not* compatible with VGA signals. The Model UV1-SL is *also* capable of extending Composite Video & Stereo Audio by setting a dip switch (see section 3.2).

2.0 Features

- Most support local monitor at sending end
- Units with multiple Cat-5 outputs
- Handles resolutions up to 1920x1440
- Drives standard CAT5 cables to 500 feet
- Rugged, Reliable, Compact size
- Transmit video and phantom power on one cable
- Adjustable cable length compensation at each receiver
- Only one power supply required for sender and all receivers

3.0 Setup and Operation

A. Place the sender near the video source and connect it to your source using the cable provided.

- For PC's VGA output use a HD15 male-to-male cable (generally a short cable may be included with your package)
- For RGB or YPbPr sources, use a HD15 to 3 RCA cable (Hall Research Model # CHD15-3RCA-length 03 = 3ft, 06 = 6 ft).
-

B. Use an Unshielded Twisted Pair (UTP) or a Shielded Twisted pair (STP) cable such as Cat5, 5e, or 6 wired per standard 568B to connect the sender to the receiver(s). See Section 3.1 for important cable selection considerations.

IMPORTANT

Do not connect this unit to any LAN device such as network cards or hubs as this may cause damage. Use EIA/TIA 568B standard straight-through patch wiring as shown below. Do not use crossover cables.

EIA/TIA 568B WIRING STANDARD	
PIN	Wire Color
1	White w/ Orange Stripe
2	Orange
3	White w/Green Stripe
4	Blue
5	White w/Blue Stripe
6	Green
7	White w/Brown Stripe
8	Brown

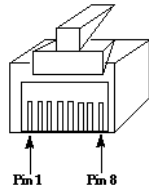

Figure 2

C. At each remote site connect a receiver (UV1-R and UV1-R-WP) to the Cat5 cable and plug your display to its HD15 output connector.

D. Plug a power supply to the System based on the type of the sender used. In general, you should connect the power supply to the Sender unit. However, follow these suggestions for best performance.

- If the sender has more than one RJ45 output (UV2-S, UV4-S, UV8-S), then the power supply must be connected to the sender.
- If the Sender is a Model UV1-S, UV1-SL, or UV1-S-WP, where the system is comprised of only one sender and one receiver, then you can plug the power supply at either the sender or the receiver.

Wallplate Power Connection

The wall plate units, UV1-S-WP and UV1-R-WP have a 2 pin screw terminal for power connection on the back of the unit. You need to connect 6 vDC (could be 6 to 9vDC) to these terminals.

In your package there is either of the 2 power supplies pictured. There is also a 2.5 mm Jack included in the package so that you don't have to cut the connector at the end of the power supply. If you decide not to cut off the power supply connector, then solder a pair of wires to the enclosed jack and connect those to the UV1-S-WP or UV1-R-WP.



Using the supplied 2.5mm Jack also gives you the ability to place the power supply outside the wall. You can use a separate single gang plate and install the supplied jack on it and wire it to the terminals on the back of the UV1-S-WP or UV1-R-WP.

You can use 20 awg or heavier wire to extend the DC output cord of the power supply if you need to locate the power supply farther from the device. It is recommended to keep the distance of the supply from the unit to within 30 feet.

Note: Please do not connect the power supply to the AC source until you have securely connected the output cords to the Wall Plate Mini-Cat unit.

Electrical Safety Note

Since the DC supply to the unit is only 6 to 9 vDC with minimal current requirements, the product qualifies as a Class 2 low-voltage device, and you are not required to run the DC cables in a conduit. However if you will be installing the power supply in the wall or ceiling, since it has to plug in to AC, you need an electrical junction box for it, and the AC line that brings high-voltage to the junction-box should follow the electrical code for your specific installation

E. Apply a video source to the system and check for an image at each receiver, then set the compensation Potentiometer (pot) for best possible image. Start with the compensation pot fully CCW (least compensation), then slowly turn it clockwise and check for the bleeding of left to right horizontal lines on the screen. See Figure 3.

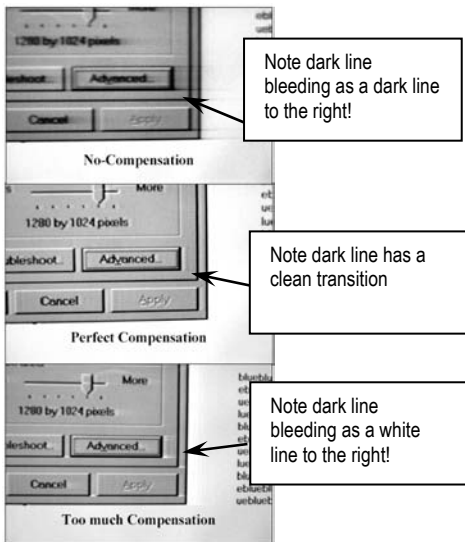

Figure 3

3.1 Important note regarding selecting the UTP Cable

First of all, UTP (unshielded) is preferred over STP (shielded) unless you are running the cable very close to AC power lines, power transformers, or ballasts of fluorescent lights, where EMI (electro-magnetic interference) can get into the video if it is strong enough.

Secondly, for best results especially for distances of over 150 feet, it is highly recommended to use a Zero-Skew Cat5 cable. (Hall Research Part Number CUTP-Z-1000).

This cable ensures that the horizontal alignment of the red, green, and blue components of the video signal is maintained regardless of the length of the Cat5 cable. In this cable, the number of twists in each of the 4 pairs in the cable is the same. If you do not use a Zero Skew cable and feel that the RGB alignment is off by an unacceptable level, then you can use a Skew Corrector (Hall Research Model SKU-RGB) at the display device if desired.

- For Cat5 runs of over 330 ft, you may need to connect a power supply to the sender as well as the receiver. This is due to the fact that the resistance of the cable causes a voltage drop from the sender to the receiver and the voltage level of the power at the receiver may not be sufficient for proper operation. This extra power supply must be ordered separately (Model 511-GS569).
- When using one supply for the system, if the power supply voltage is not enough due to the length of the Cat5 cable run, the power LED on some units may start blinking. This signifies that you need to attach another power supply to the unit that is currently being port powered.

3.2 Dip Switch Settings for the Model UV1-SL

The UV1-SL can be used to transmit Composite Video and Stereo Audio as well as VGA to the receiver. However since the Video signals are terminated differently than audio, you need to



Figure 4

move the dip switch to the proper position. Use the Mode Dip Switch to select the video type for transmission. The Sync Dip Switch is used to change the polarity of sync at the receiver. If your remote display has trouble positioning the right and left edges of the screen, then try putting the switch in the +/+ position.

4.0 Specifications

Supported Video Types:	VGA through UXGA, RGB, and YPbPr, plus CV and line level stereo audio for UV1-SL
Resolution & Refresh Rate	Up to 1920 x 1440 non-interlaced at 60Hz
Bandwidth	DC to 250 MHz
Maximum Distance	Up to 500 ft. (152 meters) for VGA and Component Video models, or 2000 ft (609m) for Composite Video and Audio models
Connectors	HD15 female for video input and output, RJ45 for CAT5 outputs
Compliance	CE; FCC Part 15 Subpart B Class A, IC Class
Power	From utility-power (mains) outlet, through included external Universal power supply. Output Voltage: 9 DC Center-Positive, <i>Do not substitute any other external power supply without contacting the factory first.</i>
Size	UV1-S: 0.8" H X 1.7" W X 4.5" L UV1-SL: 1.1" H X 2.75" W X 3.1" L UV2-S: 1.22" H x 4.86"W x 2.60"D UV4-S: 1.22" H x 8.20" W x 3.00" D UV8-S: 1.32" H x 7.58" W x 3.88" D <i>(UV8-S has 2 L-shaped mounting ears that protrude 0.88" beyond the main box on each side. 4 mounting holes are present on a rectangular pattern of 8.62" x 2.63")</i> UV1-R: 0.8" H X 1.7" W X 4.5" L



Products Designed and Made in the USA



© Copyright 2009 Hall Research, Inc. All rights reserved.

1163 Warner Ave., Tustin, CA 92780 Ph: (714) 641-6607, Fax: (714) 641-6698