

**Kramer Electronics, Ltd.**



# **USER MANUAL**

**Model:**

**VP-409**

*Video To WUXGA Scaler*

## Contents

<b>1</b>	<b>Introduction</b>	<b>1</b>
<b>2</b>	<b>Getting Started</b>	<b>1</b>
2.1	Quick Start	2
<b>3</b>	<b>Overview</b>	<b>3</b>
<b>4</b>	<b>Your VP-409 Video To WUXGA Scaler</b>	<b>4</b>
4.1	Sync Enable/Disable Output Function	5
4.2	OSD Information Enable/Disable Function	5
<b>5</b>	<b>Connecting the VP-409</b>	<b>6</b>
<b>6</b>	<b>Technical Specifications</b>	<b>7</b>

## Figures

Figure 1:	VP-409 Video To WUXGA Scaler	4
Figure 2:	Connecting the VP-409	6

## Tables

Table 1:	VP-409 Video To WUXGA Scaler Features	4
Table 2:	Technical Specifications of the VP-409	7

## 1 Introduction

Welcome to Kramer Electronics! Since 1981, Kramer Electronics has been providing a world of unique, creative, and affordable solutions to the vast range of problems that confront the video, audio, presentation, and broadcasting professional on a daily basis. In recent years, we have redesigned and upgraded most of our line, making the best even better! Our 1,000-plus different models now appear in 11 groups<sup>1</sup> that are clearly defined by function.

Congratulations on purchasing your Kramer TOOLS **VP-409** *Video To WUXGA Scaler*, which is ideal for the following typical applications:

- Multimedia and presentation applications for projecting a composite video or s-Video source using a data projector, plasma, or TFT flat-screen
- Presentation and conference room systems, boardrooms and auditoriums
- Conversion of composite/YC video to VGA format to use in RGBHV systems
- Rental and Staging

The package includes the following items:

- **VP-409** *Video To WUXGA Scaler*
- Power adapter: 5V DC Input
- This user manual<sup>2</sup>

## 2 Getting Started

We recommend that you:

- Unpack the equipment carefully and save the original box and packaging materials for possible future shipment
- Review the contents of this user manual
- Use Kramer high performance high resolution cables<sup>3</sup>

---

1 GROUP 1: Distribution Amplifiers; GROUP 2: Switchers and Matrix Switchers; GROUP 3: Control Systems; GROUP 4: Format/Standards Converters; GROUP 5: Range Extenders and Repeaters; GROUP 6: Specialty AV Products; GROUP 7: Scan Converters and Scalers; GROUP 8: Cables and Connectors; GROUP 9: Room Connectivity; GROUP 10: Accessories and Rack Adapters; GROUP 11: Sierra Products

2 Download up-to-date Kramer user manuals from our Web site at <http://www.kramerelectronics.com>

3 The complete list of Kramer cables is on our Web site at <http://www.kramerelectronics.com>

## 2.1 Quick Start

This quick start chart summarizes the basic setup and operation steps.

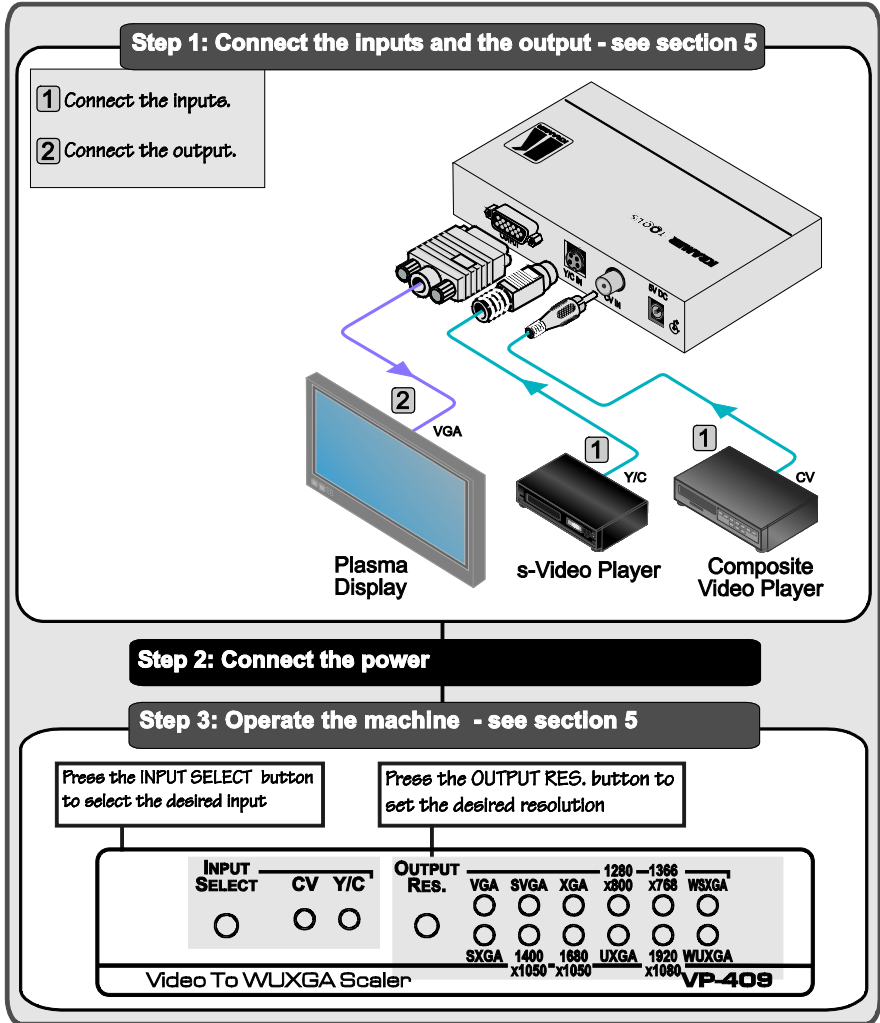

### 3 Overview

The Kramer **VP-409** is a high quality low cost converter for up-scaling composite video and s-Video to up to WUXGA. It accepts PAL-B/D/G/H/I, NTSC 3.58, and NTSC 4.43 video formats. This compact, multi-standard unit has a built-in 3D de-interlacer and a 3D comb-filter that ensures superb quality.

The **VP-409** features:

- An external DC source, making it suitable for field operation
- Side-panel buttons for selecting the input source and the output resolution – indicated by LEDs
- Non-volatile memory that retains the last setting, after switching the power off

To achieve the best performance:

- Connect only good quality connection cables, thus avoiding interference, deterioration in signal quality due to poor matching, and elevated noise-levels (often associated with low quality cables)
- Avoid interference from neighboring electrical appliances and position your Kramer **VP-409** away from moisture, excessive sunlight and dust

	<b>Caution:</b> No operator serviceable parts inside unit
	<b>Warning:</b> Use only the Kramer Electronics input power wall adapter that is provided with the unit
	<b>Warning:</b> Disconnect power and unplug unit from wall before installing or removing the device or servicing unit

## 4 Your VP-409 Video To WUXGA Scaler

Figure 1 and Table 1 define the VP-409 Video To WUXGA Scaler:

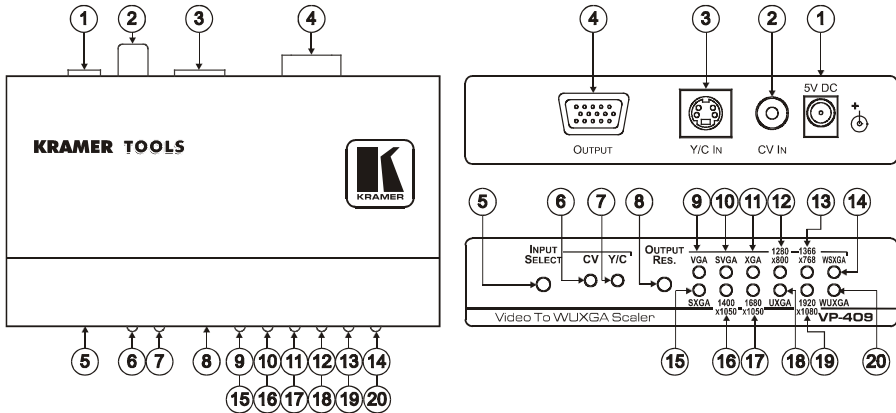

Figure 1: VP-409 Video To WUXGA Scaler

Table 1: VP-409 Video To WUXGA Scaler Features

#	Feature	Function
1	5V DC	+5V DC connector for powering the unit
2	CV IN RCA Connector	Connects to a composite video source
3	Y/C IN 4-pin Connector	Connects to an s-Video source
4	OUTPUT 15-pin HD Connector	Connects to the VGA-WUXGA acceptor
5	INPUT SELECT Button	Press to select between inputs
6	CV LED	Illuminates when the CV input is selected
7	Y/C LED	Illuminates when the Y/C input is selected
8	OUTPUT RES. Button	Press to select the desired output resolution
9	VGA LED	Illuminates when the VGA (640x480) resolution is selected
10	SVGA LED	Illuminates when the SVGA (800x600) resolution is selected
11	XGA LED	Illuminates when the XGA (1024x768) resolution is selected
12	1280x800 LED	Illuminates when the 1280x800 (Wide XGA) resolution is selected
13	1366x768 LED	Illuminates when the 1366x768 (WXGA) resolution is selected
14	WSXGA LED	Illuminates when the WSXGA (1440x900) resolution is selected
15	SXGA LED	Illuminates when the SXGA (1280x1024) resolution is selected
16	1400x1050 LED	Illuminates when the 1400x1050 (SXGA+) resolution is selected
17	1680x1050 LED	Illuminates when the 1680x1050 (WSXGA+) resolution is selected
18	UXGA LED	Illuminates when the UXGA (1600x1200) resolution is selected
19	1920x1080 LED	Illuminates when the 1920x1080 (1080p RGB) resolution is selected
20	WUXGA LED	Illuminates when the WUXGA (1920x1200) resolution is selected

## 4.1 Sync Enable/Disable Output Function

You can setup the unit to automatically disable its sync output signals<sup>1</sup> when no source is connected, so that the display/projector can enter “sleep” mode (that is, turn OFF when no sync is detected).

To toggle between the sync output enable/disable state while no input is connected, do the following:

1. Press and hold the input selection button and connect the power supply cable.
2. Hold the button until one of the input LEDs flashes for a short time (this takes about 12 seconds).

To identify the current status of the unit, disconnect and reconnect the power cable to start up the unit:

- If both INPUT LEDs flash for a short time, the sync output signals are disabled
- If both INPUT LEDs remain ON during unit startup, the sync output signals are enabled

## 4.2 OSD Information Enable/Disable Function

To toggle between enabling/disabling the OSD information:

1. Press and hold the OUTPUT RES. selection button and connect the power supply cable.
2. Hold the button until all the resolution LEDs flash for a short time. (This takes about 12 seconds).

---

<sup>1</sup> The syncs are disabled after no video is detected for a period of about 2 minutes

## 5 Connecting the VP-409

To connect the VP-409, as illustrated in the example in [Figure 2](#), do the following<sup>1</sup>:

1. Connect a composite video source to the CV IN RCA connector (for example, a composite video player) and/or an s-Video source (for example, an s-Video player) to the Y/C 4-pin input connector.
2. Connect the OUTPUT 15-pin HD computer graphics video connector to an acceptor (for example, a plasma display).
3. Connect the 5V DC power adapter to the power socket and connect the adapter to the mains electricity (not shown in [Figure 2](#)).
4. Use the:
  - INPUT SELECT button to select the desired input
  - OUTPUT RES. button to select the desired resolution

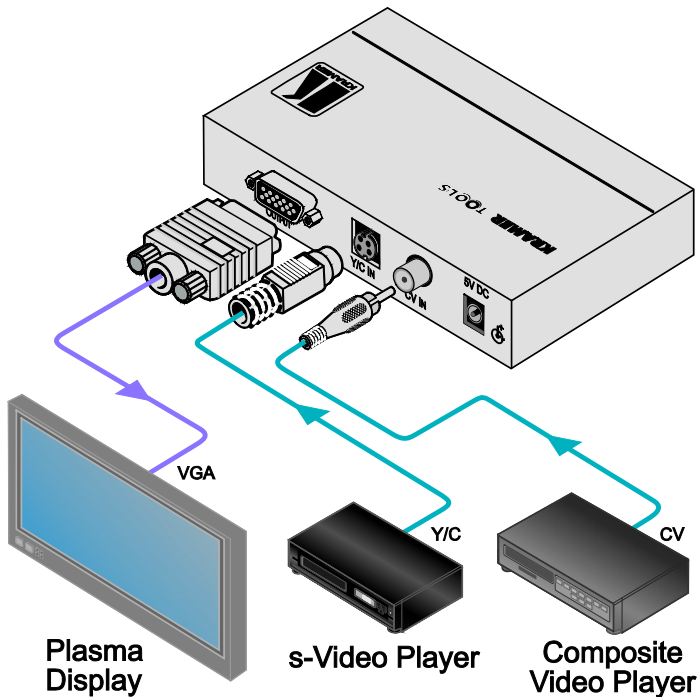

Figure 2: Connecting the VP-409

<sup>1</sup> Switch OFF the power on each device before connecting it to your VP-409. After connecting your VP-409, switch on its power and then switch on the power on each device



## 6 Technical Specifications

[Table 2](#) includes the technical specifications<sup>1</sup>:

*Table 2: Technical Specifications of the VP-409*

INPUTS:	1 CV 1Vpp/75Ω on an RCA connector 1 Y/C 1Vpp (Y); 0.3Vpp (C)/75Ω on a 4-pin connector
OUTPUT:	1 VGA (VGA through WUXGA) on a 15-pin HD computer graphics video connector
OUTPUT RESOLUTIONS:	VGA, SVGA, XGA, 1280x800, 1366x768, WSXGA, SXGA, 1400x1050, 1680x1050, UXGA, 1920x1080, and WUXGA
OUTPUT REFRESH RATE:	60Hz
CONTROLS:	Pushbuttons and LEDs for selection of Input Source and Output Resolution
POWER SOURCE:	5V DC, 450mA
DIMENSIONS:	12cm x 7.5cm x 2.5cm (4.7" x 2.95" x 0.98", W, D, H)
WEIGHT:	0.3kg (0.67lbs) approx.
ACCESSORIES:	Power supply (5V)
OPTIONS:	RK-3T 19" rack adapter

<sup>1</sup> Specifications are subject to change without notice

---

## LIMITED WARRANTY

Kramer Electronics (hereafter *Kramer*) warrants this product free from defects in material and workmanship under the following terms.

### HOW LONG IS THE WARRANTY

Labor and parts are warranted for seven years from the date of the first customer purchase.

### WHO IS PROTECTED?

Only the first purchase customer may enforce this warranty.

### WHAT IS COVERED AND WHAT IS NOT COVERED

Except as below, this warranty covers all defects in material or workmanship in this product. The following are not covered by the warranty:

1. Any product which is not distributed by Kramer, or which is not purchased from an authorized Kramer dealer. If you are uncertain as to whether a dealer is authorized, please contact Kramer at one of the agents listed in the Web site [www.kramerelectronics.com](http://www.kramerelectronics.com).
2. Any product, on which the serial number has been defaced, modified or removed, or on which the WARRANTY VOID IF TAMPERED sticker has been torn, reattached, removed or otherwise interfered with.
3. Damage, deterioration or malfunction resulting from:
  - i) Accident, misuse, abuse, neglect, fire, water, lightning or other acts of nature
  - ii) Product modification, or failure to follow instructions supplied with the product
  - iii) Repair or attempted repair by anyone not authorized by Kramer
  - iv) Any shipment of the product (claims must be presented to the carrier)
  - v) Removal or installation of the product
  - vi) Any other cause, which does not relate to a product defect
  - vii) Cartons, equipment enclosures, cables or accessories used in conjunction with the product

### WHAT WE WILL PAY FOR AND WHAT WE WILL NOT PAY FOR

We will pay labor and material expenses for covered items. We will not pay for the following:

1. Removal or installations charges.
2. Costs of initial technical adjustments (set-up), including adjustment of user controls or programming. These costs are the responsibility of the Kramer dealer from whom the product was purchased.
3. Shipping charges.

### HOW YOU CAN GET WARRANTY SERVICE

1. To obtain service on your product, you must take or ship it prepaid to any authorized Kramer service center.
2. Whenever warranty service is required, the original dated invoice (or a copy) must be presented as proof of warranty coverage, and should be included in any shipment of the product. Please also include in any mailing a contact name, company, address, and a description of the problem(s).
3. For the name of the nearest Kramer authorized service center, consult your authorized dealer.

### LIMITATION OF IMPLIED WARRANTIES

All implied warranties, including warranties of merchantability and fitness for a particular purpose, are limited in duration to the length of this warranty.

### EXCLUSION OF DAMAGES

The liability of Kramer for any effective products is limited to the repair or replacement of the product at our option. Kramer shall not be liable for:

1. Damage to other property caused by defects in this product, damages based upon inconvenience, loss of use of the product, loss of time, commercial loss; or:
2. Any other damages, whether incidental, consequential or otherwise. Some countries may not allow limitations on how long an implied warranty lasts and/or do not allow the exclusion or limitation of incidental or consequential damages, so the above limitations and exclusions may not apply to you.

This warranty gives you specific legal rights, and you may also have other rights, which vary from place to place.

**NOTE:** All products returned to Kramer for service must have prior approval. This may be obtained from your dealer.

This equipment has been tested to determine compliance with the requirements of:

- EN-50081: "Electromagnetic compatibility (EMC); generic emission standard.  
Part 1: Residential, commercial and light industry"
- EN-50082: "Electromagnetic compatibility (EMC) generic immunity standard.  
Part 1: Residential, commercial and light industry environment".
- CFR-47: FCC\* Rules and Regulations:  
Part 15: "Radio frequency devices  
Subpart B Unintentional radiators"

### CAUTION!

- Servicing the machines can only be done by an authorized Kramer technician. Any user who makes changes or modifications to the unit without the expressed approval of the manufacturer will void user authority to operate the equipment.
- Use the supplied DC power supply to feed power to the machine.
- Please use recommended interconnection cables to connect the machine to other components.  
\* FCC and CE approved using STP cable (for twisted pair products)



---

**For the latest information on our products and a list of Kramer distributors, visit our Web site: [www.kramerelectronics.com](http://www.kramerelectronics.com), where updates to this user manual may be found. We welcome your questions, comments and feedback.**



**Caution**

**Safety Warning:**

Disconnect the unit from the power supply before opening/servicing.



---

**Kramer Electronics, Ltd.**

Web site: [www.kramerelectronics.com](http://www.kramerelectronics.com)

E-mail: [info@kramerelect.com](mailto:info@kramerelect.com)

P/N: 2900-000619 REV 2