

MANUAL PART NUMBER: 400-0365-002

MX2106AV

2X2 VGA + 3.5mm AUDIO AUTO-SWITCHER USER'S GUIDE

TABLE OF CONTENTS

	Page
PRECAUTIONS / SAFETY WARNINGS	2
GENERAL.....	2
INSTALLATION	2
CLEANING	2
FCC / CE NOTICE	2
ABOUT YOUR SWITCHER.....	3
TECHNICAL SPECIFICATIONS	3
DESCRIPTION OF MX2106AV	4
APPLICATION DIAGRAM	5
DIAGRAM 1: TYPICAL CONFIGURATION.....	5
DIAGRAM 2: INTERNAL VIEW.....	6
INSTALLING YOUR SWITCHER	7
OPERATION.....	7
TROUBLESHOOTING GUIDE	8
LEDs ARE OFF.....	8
UNIT DOES NOT AUTO-SWITCH.....	8
NO DISPLAY	8
ALTINEX POLICY	9
LIMITED WARRANTY/RETURN POLICY.....	9
CONTACT INFORMATION.....	9

PRECAUTIONS / SAFETY WARNINGS 1

Please read this manual carefully before using your **MX2106AV** Switcher. Keep this manual handy for future reference. These safety instructions are to ensure the long life of your **MX2106AV** and to prevent fire and shock hazard. Please read them carefully and heed all warnings.

1.1 GENERAL

- Qualified ALTINEX service personnel, or their authorized representatives must perform all service.

1.3 INSTALLATION

- For best results, place the **MX2106AV** on a flat, level surface. Keep in a dry area away from dust and moisture.
- To prevent fire or shock, do not expose this unit to rain or moisture. Do not place the **MX2106AV** in direct sunlight, near heaters or heat radiating appliances, or near any liquid. Exposure to direct sunlight, smoke, or steam can harm internal components.
- Handle the **MX2106AV** carefully. Dropping or jarring can damage internal components.
- Do not place heavy objects on top of the **MX2106AV**.
- To turn off the main power, be sure to remove the cord from the power outlet. The power outlet socket should be installed as close to the equipment as possible, and should be easily accessible.
- Do not pull the power cord or any cable that is attached to the **MX2106AV** Switcher.
- If the **MX2106AV** is not used for an extended time, disconnect power cord from the outlet.

1.4 CLEANING

- Unplug the **MX2106AV** power cord before cleaning. Clean surfaces with a dry cloth. Never use strong detergents or solvents, such as alcohol or thinner. Do not use a wet cloth or water to clean the unit.

1.5 FCC / CE NOTICE

- This device complies with Part 15 of FCC Rules. Operation is subject to the following two conditions: (1) This device may not cause harmful interference, and (2) this device must accept any interference, including interference that may cause undesired operation.
- This equipment has been tested and found to comply with the limits for a Class A digital device, pursuant to Part 15 of FCC Rules. These limits are designed to provide reasonable protection against harmful interference when equipment is operated in a commercial environment. This equipment generates and uses radio frequency energy. If not installed and used in accordance with the instruction manual, it may cause harmful interference to radio communications. Operation of this equipment in a residential area is likely to cause harmful interference in which case the user will be required to correct the interference at his own expense.
- Any changes or modifications to the unit not expressly approved by Altinex, Inc. could void the user's authority to operate the equipment.

ABOUT YOUR SWITCHER 2

MX2106AV 2-In, 2-Out VGA+3.5mm AUDIO Auto-Switcher

The **MX2106AV** is a 2-In, 2-Out VGA + 3.5mm AUDIO Auto-Switcher. The **MX2106AV** automatically switches on signal detection, but may also be controlled manually if desired. The **MX2106AV** is designed to switch VGA signals and stereo audio.

The unit is encased in a solid metal enclosure and ships with an external, 9V 500mA, power adapter.

Override switching is made through the INPUT SELECT/RS-232 input. Manual override switching is made via a contact closure on the INPUT SELECT jack. This switch may be used for manual control, or the contact closure may be controlled from a control system. RS-232 control is accomplished by sending ASCII commands to select either Input 1 or Input 2.

TECHNICAL SPECIFICATIONS 3

FEATURES/DESCRIPTION	MX2106AV
Inputs	Two
VGA	(2) 15 Pin HD Female
Audio	(2) 3.5mm Jack
Control	3.5mm Jack
Outputs	Two
VGA	(2) 15 Pin HD Female
Audio	(2) 3.5mm Jack
Compatibility	Audio + VGA thru UXGA

Table 1. **MX2106AV** General

MECHANICAL	MX2106AV
Material	0.1" Al
Finish	Black
Height (inches)	4.40in (112mm)
Width (inches)	4.08in (104mm)
Depth (inches)	1.00in (25mm)
Weight (pounds)	0.4lbs (0.18kg)
Ship Weight (pounds)	2.0lbs (0.91kg)
T° Operating	10°C-35°C
T° Maximum	50°C
Humidity	90% non-condensing
MTBF (calculations)	40,000 hrs (min.)

Table 2. **MX2106AV** Mechanical

ELECTRICAL	MX2106AV
Video Input Signal	
Video Signal	1.5V p-p max
Video Impedance	75 Ohms
SYNC Signal	TTL (+/-)
SYNC Impedance	10K Ohms
Audio Input Signal	
Impedance	10K Ohms
Level	0dB
Video Output Signals	
Video Gain	1.05
Video Impedance	75 Ohms
Sync Signal	TTL (+/-)
Frequency Compatibility	
Horizontal	15-200 kHz
Vertical	20-190 Hz
Typical Video Bandwidth	350 MHz @ -3dB
Cross-talk	-40dB @10 MHz
Coupling	DC
Audio Output Signals	
Impedance	75 Ohms
Gain	0dB
Power	
External Power Adapter	9V 500mA (included)
Power Consumption	3 watts max.

Table 3. **MX2106AV** Electrical

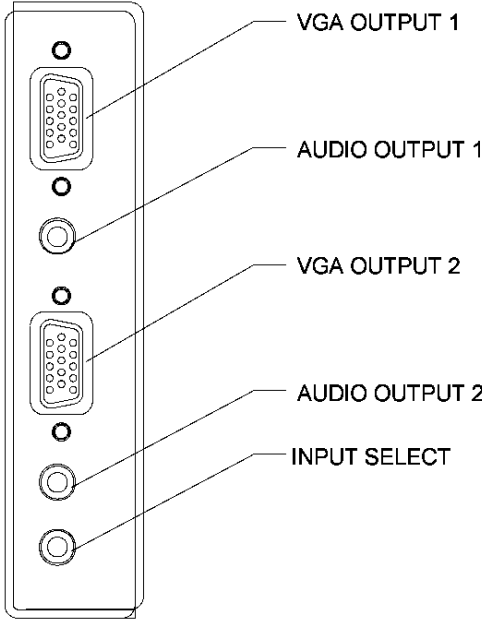
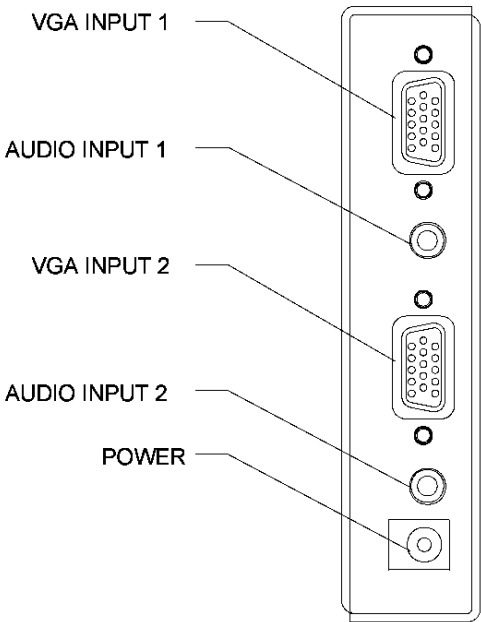
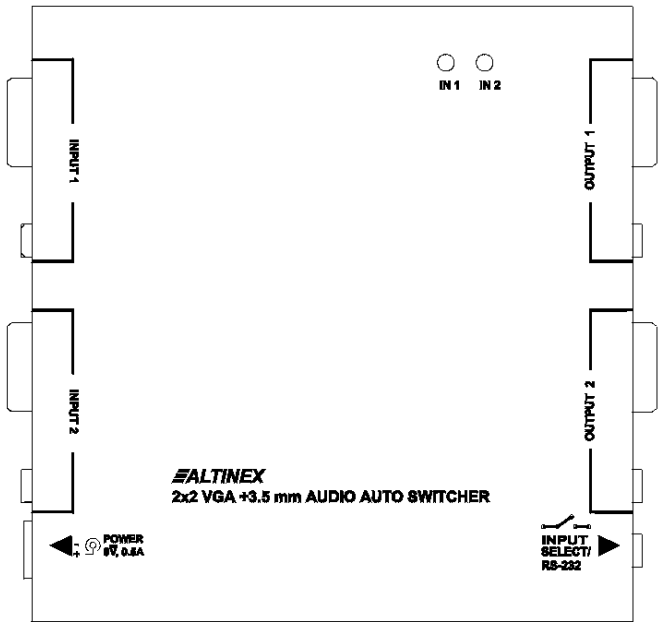

APPLICATION DIAGRAM

5

DIAGRAM 1: TYPICAL CONFIGURATION

In addition to automatic switching, the MX2106AV may be controlled manually with an external switch, or using ASCII commands over the RS-232 bus.

If a remote switch is connected to the INPUT SELECT jack, INPUT 1 will be selected when the contact is open. INPUT 2 will be selected if the channel select contact is closed. If the RS-232 cable is connected, the user may send the command [ON1] to select input 1 or [ON2] to select input 2.

Auto-switching is disabled with either manual or RS-232 control. The switching will be identical whether there are one or two active signals. The indicator lights located next to the input ports indicate which input is selected.

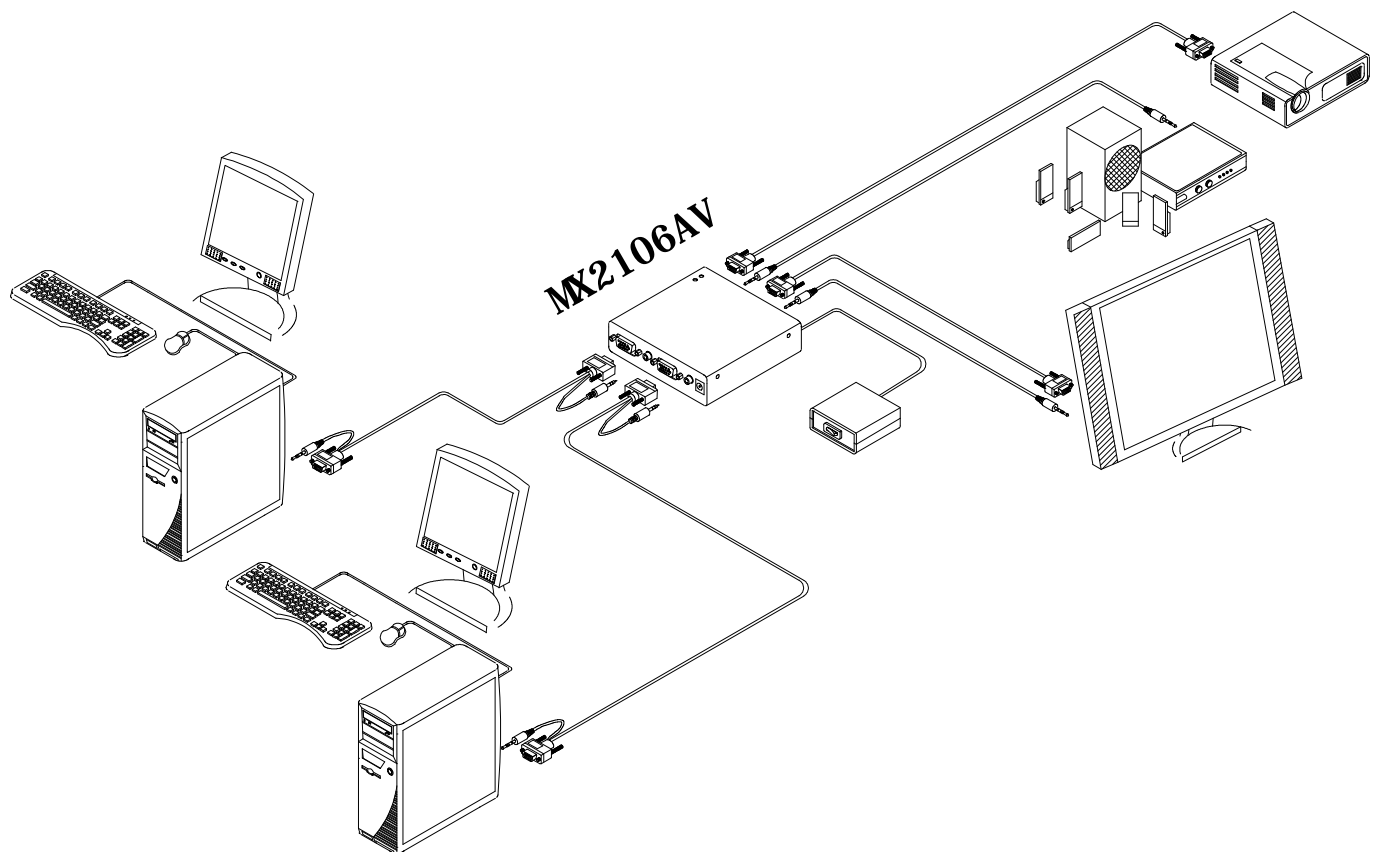
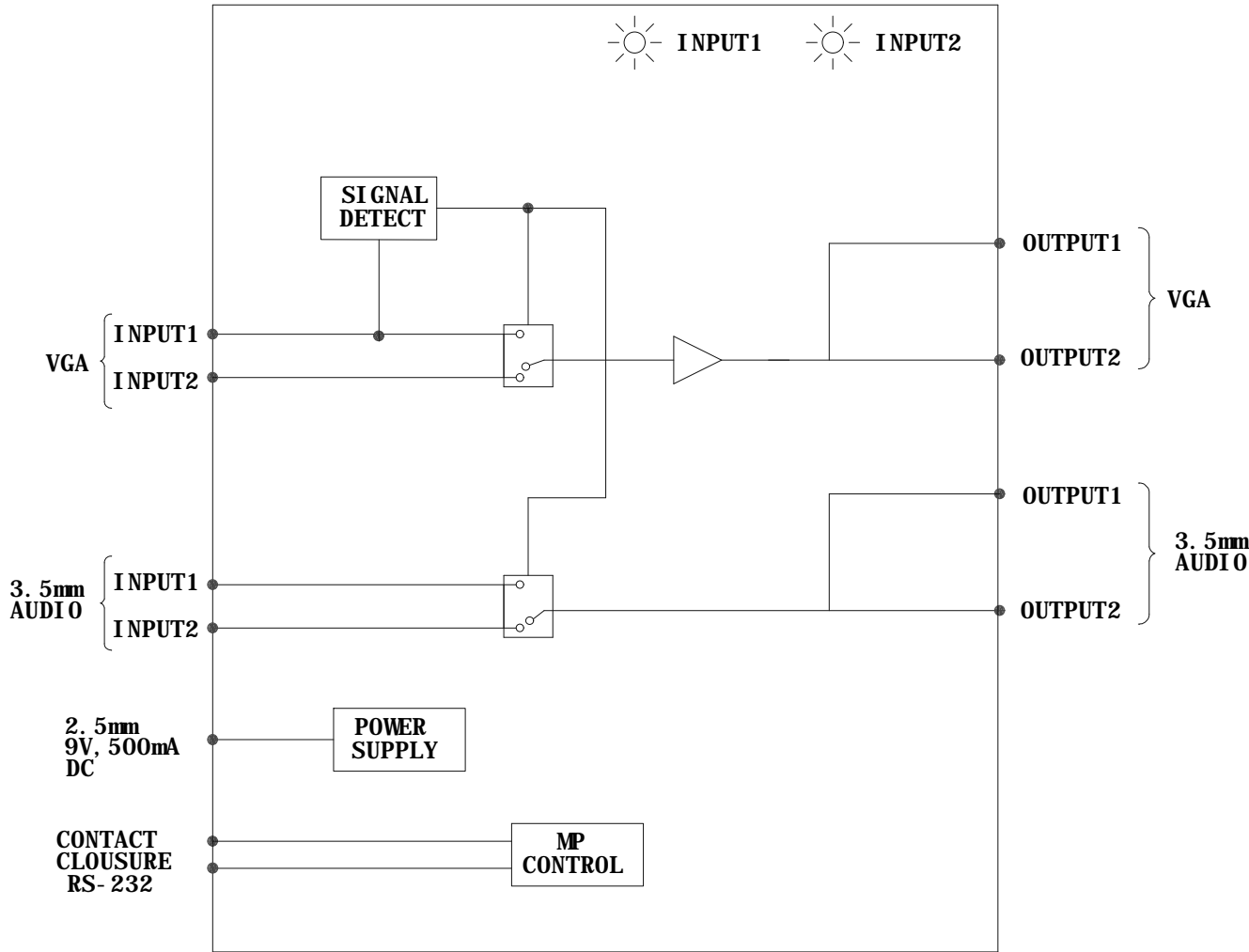

DIAGRAM 2: INTERNAL VIEW



INSTALLING YOUR SWITCHER 6

Step 1. Make sure that the correct power adapter is used. The Altinex power adapter is supplied with the unit. Connect the power adapter to the power port. The INPUT 2 indicator light should be ON and GREEN.

NOTE: INPUT 2 is the default if there is no signal on INPUT 1.

Step 2. Connect the VGA source or sources to the **MX2106AV** inputs. If there is a properly formatted input signal on Input 1, the switcher will switch Input 1 to the outputs automatically.

Step 3. Connect a cable from one or both of the output ports on the **MX2106AV** to display devices.

Step 4. If a remote switch or RS-232 control is to be used, connect the control cable to the INPUT SELECT/RS-232 port. See Section 7 for specific control functions.

NOTE: See **Figure 1** below for cabling information. The INPUT SELECT/RS-232 port receives a 3.5mm Stereo Plug.

Step 5. Verify that the picture quality on the display is good. If a signal is not being received, make sure that the display is compatible with the resolution of the computer graphics card.

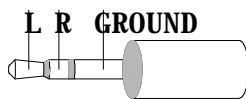

Figure 1

CONTROL	L	R	GND
Remote Switch	n/a	Switch Pole	Switch Throw
RS-232 DP9 Male	Pin 3 TX	n/a	Pin 5 GND

OPERATION 7

There are no settings to adjust on the **MX2106AV** Auto-Switcher. The **MX2106AV** will operate successfully as long as cables are attached properly and other specifications are followed.

AUTO-SWITCH MODE

The **MX2106AV** automatically selects INPUT 2 if no active signals present. If a signal is on INPUT 2 and not on INPUT 1, the **MX2106AV** will maintain INPUT 2. However, when an active signal is applied to INPUT 1, the **MX2106AV** will switch to INPUT 1. If active signals are on both inputs, the **MX2106AV** will automatically switch to INPUT 1.

MANUAL SWITCH MODE

Manual override is accomplished via a contact closure on the INPUT SELECT/RS-232 jack. Manual Switch Mode disables Auto-Switching.

This switch may be used for manual control, or the contact closure may be made from a control system.

INPUT 1 will be selected when the remote control switch is connected to the INPUT SELECT jack and the contact is open. INPUT 2 will be selected if the contact is closed.

RS-232 SWITCH MODE

The **MX2106AV** may be switched using simple ASCII commands through standard RS-232 communication. Connect the RS-232 cable to the INPUT SELECT/RS-232 jack. In RS-232 Control Mode, Auto-Switching is disabled. Send the following commands over the RS-232 bus to select the desired input.

[ON1] = Select INPUT 1

[ON2] = Select INPUT 2

NOTE: The "[" and "]" brackets are part of the command and must be included.

CABLE/ACCESSORIES

Cable accessories for RS-232 Control and Remote switching are available from Altinex.

We have carefully tested and have found no problems in the supplied **MX2106AV** unit. However, we would like to offer the following suggestions:

8.1 LEDs ARE OFF

Cause 1: The power adapter is installed wrong.

Solution 1: Make sure the adapter output is connected to the POWER input jack on the unit. If one of the LEDs is still not on, see Solution 2.

Solution 2: Ensure the adapter is plugged into an AC outlet that has power. If the adapter has AC power and the LEDs are still off, see Cause 2.

Cause 2: The wrong power adapter is installed.

Solution 1: Please use the Altinex supplied external adapter (9V, 500mA). If one of the LEDs is still not on, please call ALTINEX at (714) 990-2300.

8.2 UNIT DOES NOT AUTO-SWITCH

Cause 1: The manual override switch is installed.

Solution: Remove the connection to the INPUT SELECT jack on the unit. If a plug is installed in the jack, even without a switch, the unit will not auto-switch properly. If the unit does not auto-switch with the plug removed, see Cause 2.

Cause 2: The signal is not active or is improperly formatted.

Solution 1: Remove the input signals from the switcher. If the IN 2 LED is OFF, call ALTINEX at (714) 990-2300. If the IN 2 LED is ON, see Solution 2.

Solution 2: Connect a properly formatted VGA type signal from to INPUT 1. If the switcher does not switch to INPUT 1, see Solution 3.

Solution 3: Bypass the switcher and connect the output of the source directly to the display. If the display is good, then call ALTINEX at (714) 990-2300.

8.3 NO DISPLAY

Cause 1: The source has a problem.

Solution: Check the source and make sure that there is a signal present and all source connections are correct. If the source is working and there is still no display, see Cause 2.

Cause 2: Manual override is ON.

Solution: Make sure there is nothing connected to the INPUT SELECT port on the switcher. If there is nothing connected, see Cause 3.

Cause 3: Signal is bad or missing.

Solution 1: Make sure the switcher output is connected to the monitor. If there is still no display, see Solution 2.

Solution 2: Remove both inputs to the switcher and connect the active signal from the source to INPUT 2. If there is still no display, see Solution 3.

Solution 3: Bypass the switcher and connect the output of the source directly to the monitor. If the display is good, then call ALTINEX at (714) 990-2300. If there is still no display, see Cause 4.

Cause 4: Cable connections are incorrect.

Solution: Make sure the cables are properly connected. Also, make sure that the continuity and wiring are good. If there is still no display present, see Cause 5.

Cause 5: The display has a problem.

Solution: Make sure the display has power and is turned ON. If there is still no display, please call Altinex at (714) 990-2300.

ALTINEX POLICY

9

9.1 LIMITED WARRANTY/RETURN POLICY

Please see the Altinex website at www.altinex.com for details on warranty and return policy.

9.2 CONTACT INFORMATION

ALTINEX, INC

592 Apollo street

Brea, CA 92821 USA

TEL: 714 990-2300

TOLL FREE: 1-800-ALTINEX

WEB: www.altinex.com

E-MAIL: solutions@altinex.com