



INSTRUCTION MANUAL

FOCN Series

Fiber Optic Compact Node

Model	Stock No.
FOCN-S4S-201	7420A-1
FOCN-S4S-204	7420A-4
FOCN-S4S-205	7420A-5

Status	Date	Document No.	Issue No.	Author
Active	September 28, 2010	651215000C	3	KK
Obsolete	May 15, 2009	651215000B	2	KK



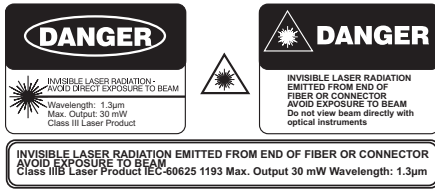

Warning: The optical emissions from the units are laser-based and present eye hazards. Follow all safety precautions

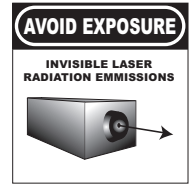

INVISIBLE LASER RADIATION EMITTED FROM END OF FIBER OR CONNECTOR
AVOID EXPOSURE TO BEAM
Class IIIb Laser Product IEC-60625 1193 Max. Output 30 mW Wavelength: 1.3um

**TO REDUCE THE RISK OF ELECTRICAL SHOCK, DO NOT REMOVE COVER FROM THIS UNIT.
NO USER-SERVICEABLE PARTS INSIDE. REFER SERVICING TO QUALIFIED SERVICE PERSONNEL.**

Safety Precautions

The optical emissions from the units are laser-based Class IIIb, and may present eye hazards if improperly used. **NEVER USE ANY KIND OF OPTICAL INSTRUMENT TO VIEW THE OPTICAL OUTPUT OF THE UNIT.**

As always, be careful when working with optical fibers. Fibers can cause painful injury if they penetrate the skin.

Laser Safety Procedures

ALWAYS read the product data sheet and the laser safety label before powering the product. Note the operating wavelength, optical output power, and safety classifications.

If safety goggles or other eye protection are used, be certain that the protection is effective at the wavelength(s) emitted by the device under test **BEFORE** applying power.

ALWAYS connect a fiber to the output of the device **BEFORE** power is applied. Power should never be applied without an attached fiber output. If the device has a connector output, a connector should be attached that is connected to a fiber. This ensures that all light is confined within the fiber waveguide, virtually eliminating all potential hazard.

NEVER look in the end of a fiber to see if light is coming out. **NEVER!** Most fiber optic laser wavelengths (1310 nm and 1550 nm) are totally invisible to the unaided eye and will cause permanent damage. Shorter wavelength lasers (e.g. 780 nm) are visible and are very damaging. Always use instruments, such as an optical power meter, to verify light output.

NEVER, NEVER, NEVER look into the end of a fiber on a power device with ANY sort of magnifying device. This includes microscopes, eye loupes, and magnifying glasses. This **WILL** cause permanent, irreversible burn on your retina. Always double check that power is disconnected before using such devices. If possible, completely disconnect the unit from any power source.

If you have questions about laser safety procedures, please call Blonder Tongue before powering your product.

Laser safety classes for the FOCN:

Class	Wavelength Range	Optical Power Accession Limits
IIIb	180 nm to 400 nm 400 nm to 10 ⁶ nm	Varies with λ and exposure time. 0.5 Watt

Storing the Unit

If a unit is to be out of use for an extended period of time, the following steps should be taken to ensure the preservation of the unit:

1. The storage temperature range is -20°C to +70°C.
2. A low humidity environment is preferable for long term storage.
3. All connectors should be covered with active device receptacle caps.

Description

The Blonder Tongue FOCN is a high quality, cost effective, bidirectional CATV node featuring the latest optical receiver technology. It is designed to operate with optical input levels ranging from -8dBm to +2dBm. The FOCN has a forward bandwidth of 54-1000 MHz and 5-42 MHz Return with Optional Return Laser Transmitters.

FOCN Model Table

Model	Stock No.	Description
FOCN-S4S-201	7420-1	Rx Only (No Return)
FOCN-S4S-204	7420-4	Rx with 1310 nm, 4.8 dBm DFB Laser
FOCN-S4S-205	7420-5	Rx with 1550 nm, 4.0 dBm DFB Laser

The FOCN comes with an AC adapter which operates on an input of 100-240 VAC 50/60 Hz and an output of 12 VDC at 1.25 Amps.

Installation/Environmental Considerations

The FOCN is specified to operate from -10°C to +55°C. It should be mounted in an adequately ventilated area. For a longer life span, it should not be operated at the upper limit of the temperature range. Installation in wet areas or areas of extremely high humidity should be avoided. The FOCN should not be installed in areas that are accessible to children.

The FOCN may be installed and operated in any position on a flat surface. The unit has two slots in the bottom plate to accommodate mounting hardware. The unit should be mounted by sliding over one screw and then tightening the other screw. If mounting requires a wood screw, use #6 or #8 (maximum) pan-head sheet metal screws. These are commonly available at hardware stores. If mounting with a machine screw (to tapped holes), use 6-32 pan-head screws.

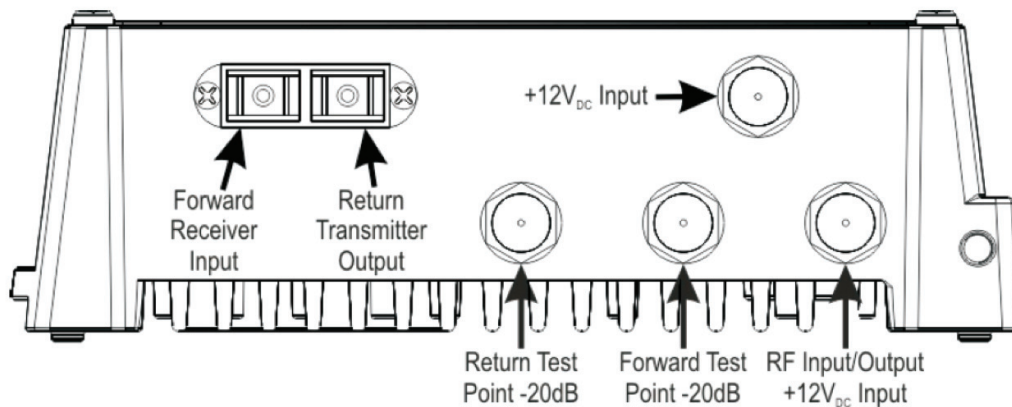

Optical Connectors

The optical connectors are available in SC/APC type terminations.

Powering

Apply only +12 VDC to either the “F” connector closest to the top cover of the unit, or through a power inserter in series with the Main RF output connector, the “F” connector closest to the outside edge of the housing.

NOTE: the center conductor of the “F” connector is “+” and the shield is ground.

Specifications

Forward Optical Receivers

RF Output

Frequency Range (+/- 1.0 dB): 54-1000 MHz (NTSC)

Output Level (@ -1 dBm optical input):*
+28 dBmV (@ 550 MHz)

Return Loss: 14 dB min., 16 dB typical

Impedance: 75 Ohm

CNR (@ 0 dBm optical input):* > 53 dB

CSO (@ -1 dBm optical input):* > 63 dBc

CTB (@ -1 dBm optical input):* > 65 dBc

Slope: 0dB

RF Test Point (forward) -20 dB; Type F

Optical

Wavelength: 1280 - 1610 nm

Optical Input Power Range: +2 dBm to -8 dBm

Return Loss: > 50 dB with APC connector

Optical Input Power Test Point:
1 V/mW +/- 0.1 V

Optical Connector: SC/APC, 8° APC

* NOTE: Typical levels @ 0 dB slope to 1000 MHz with 8dBm optical transmitter with OMI @ 3.2%, & 77 NTSC channel loading to 550 MHz & digital loading to 1000 MHz (-6 dB below analog).

Electrical & Mechanical

Dimensions: 3" H x 6" D x 2.1" H

Weight: 12 oz.

Operating Temperature Range:
-10 to +55°C (temperature at the mounting plate)

Enclosure IP Rating: IP20

Powering: +12 VDC
(via external Power Supply (included))

DC Ripple: < 50 mV

Power Dissipation (with return TX): < 7 W

Return Optical Transmitters

F-P & DFB Versions RF Input

Frequency Range: (+/- 1.0 dB) 5-42 MHz (NTSC)

RF Test Point (return): -20 dB (external); Type F

Return Loss (with Return TX Installed):
> 16 dB within the Return Band

Return Path NPR: 15 dB min. of NPR Range

FP: 37 dB NPR Threshold

DFB: 41 dB NPR Threshold

Optical

Optical Output:

DFB = 4.8dBm (3mW) @1310nm

DFB = 4.0dBm (2.5mW) @1550nm

Return Loss: > 50 dB with APC connector

Optical Connector SC/APC, 8° APC

Operational Setup – Receiver (Forward Path)

The FOCN optical receiver as the last component in a specific optical link will provide carrier-to-noise performance and an RF output level that is dependent on several parameters. The RF input level to the source optical transmitter and the optical input level to the FOCN basically determine the link performance.

Both the laser modulation and the receiver output level are basically limited by total power. The RF input level to any optical transmitter is dependent on the number of channels being transmitted. As the number of carried channels is lowered, the RF input level to the transmitter can be raised. This results in increased RF levels at the FOCN receiver. This improves the carrier-to-noise ratio over the link. Links should be designed and transmitters should be set up using values that represent the maximum number of channels likely to be carried.

The following chart assumes approximately 77 channels from 55 MHz to 550 MHz and digital loading from 550 MHz to 1000 MHz at -6dB below analog. The RF levels are measured at 547.25 MHz.

Optical Input Level	Received Power @ T.P	Approx. Forward T.P. Level	Approx. RF Output Level
-8 dBm	.16V	-6 dBmV	14 dBmV
-6 dBm	.25V	-2 dBmV	18 dBmV
-4 dBm	.40V	2 dBmV	22 dBmV
-2 dBm	.63V	6 dBmV	26 dBmV
0 dBm	1.0V	10 dBmV	30 dBmV
+2 dBm	1.58V	14 dBmV	34 dBmV

Although the node will operate at optical input levels as high as +2 dBm, there is little improvement in the C/N performance of the node at optical input levels above 0 dBm. For optimum distortion performance it is recommended that the optical input to the node be kept at or below 0 dBm. The FOCN's RF output is directly proportionate to the optical input level. If lower output is desired, the unit should be lowered by adding an in-line pad to the RF output to reduce the output level. This will maintain optimum C/N performance. This will also reduce the OMI of the return transmitter if so equipped.

The following chart shows the approximate C/N performance at various input levels and channel loading. This performance can vary considerably depending upon fiber and laser performance so it is presented as a design aid only.

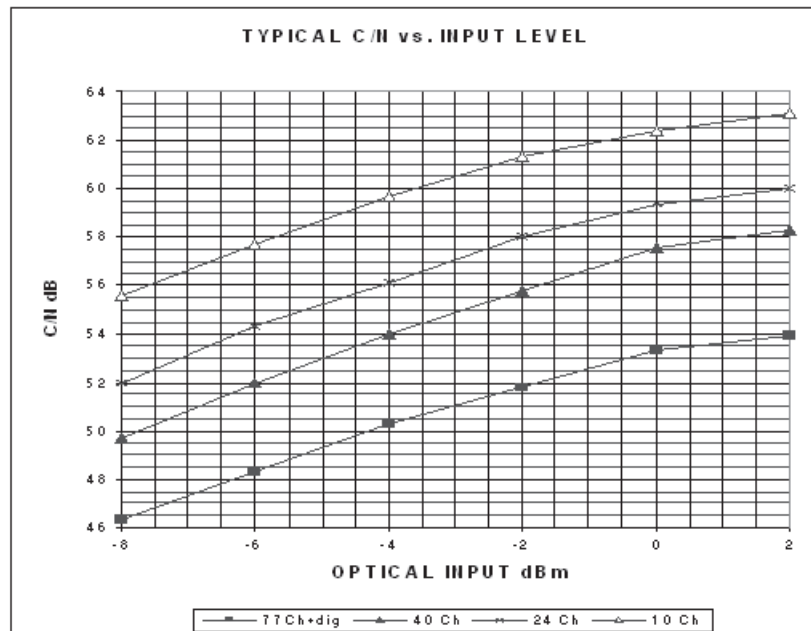

Internal Adjustments

The FOCN receiver has two user adjustments inside the unit. One is used to change the Forward Receive level test point calibration between 1310nm and 1550nm optical input ranges. The other is to set the OMI of the return band transmitter, (if equipped) this will be discussed later on. The unit should not be operated for extended periods with the top cover removed. This is because of RF ingress and contamination from dirt or other objects. When replacing the top cover, be sure to firmly tighten all thumbscrews. RF ingress or oscillation can be caused by loose screws.

The locations of the internal adjustments are shown in the following diagram.

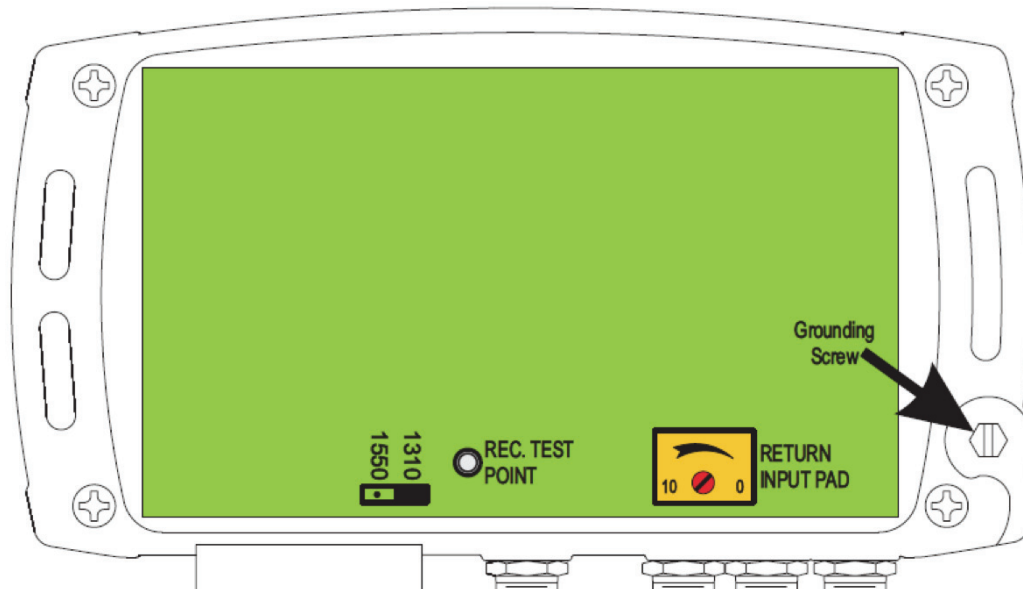

Return Transmitter Setup

The specification for the return band transmitter RF input level is -58 dBmV/Hz (measured at FOCN RF Out Port). This value operates the system at NPR threshold. The FOCN has an adjustable attenuator in the return path. Also included is a -20 dB test point in the return path. The single carrier equivalent of -57 dBmV/Hz is $+9 \text{ dBmV}$. The return pad must be adjusted to set the carrier to $+9 \text{ dBmV}$ actual after the attenuator. With a test carrier present at the port ($+19 \text{ dBmV}$ max), measure its level at the return -20 dB test point. Adjust the pad for a -20 dB test point reading of -11 dBmV return input.

External Test Points

The FOCN has three external test points. The received "Optical Power" test point is calibrated at 1 V per mW @ 1310 nm , it should be measured with a high impedance voltmeter. This test point is for long term monitoring purposes as well as initial setup. The optical power should be measured with a power meter at the time of installation. The input test point is calibrated at the factory at 1310 nm . The value at 1550 nm may be off by 15% due to diode variations. The input test point reading will be considerably off if the input wavelength is 1550 nm and the internal jumper has not been changed. The jumper is located inside the unit next to the receive level test point as shown above. The position closest to the test point is for 1310 nm , and the position farther from the test point is for 1550 nm .

The Forward Test Point is -20 dB from the RF output of the receiver. If the RF out is $+28 \text{ dBmV}$, then the test point should be approximately $+8 \text{ dBmV}$.

The Return Test Point is -20 dB from the RF input going to the return transmitter. Optimal input should be $+14 \text{ dBmV}$, so the test point should read -6 dBmV .

System Setup & Trouble Shooting

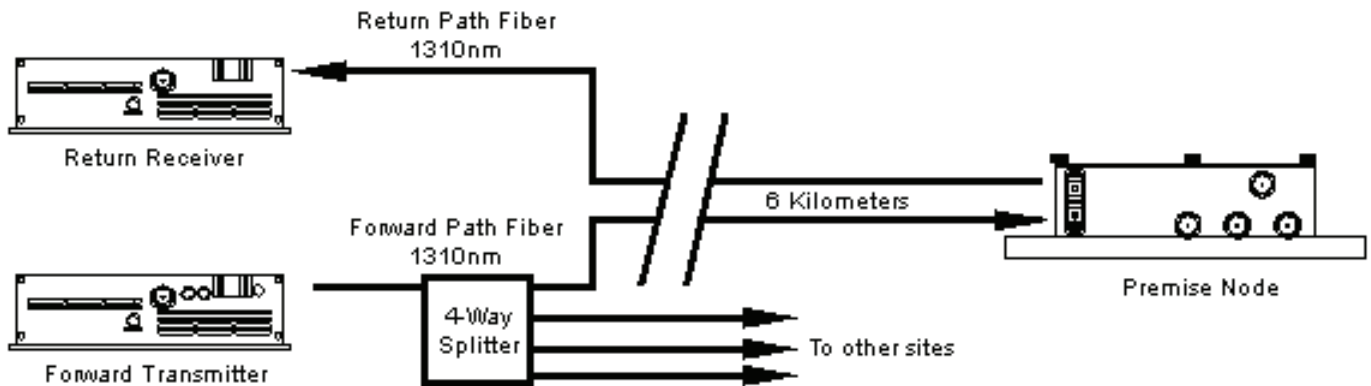

Fiber Loss at 1310nm is 0.330 dB per kilometer, and 1550 is 0.188 dB per kilometer. Using this formula, if the fiber run is 6 kilometers (3.73 miles), then a 2dBm transmitter is required for the distance. If the forward band is being split, then the additional loss must be accounted for. A fiber splitter generally splits the signal equally between each output. If the forward path is to be split 4 ways, then a transmitter with an output power of 8dBm will be required to travel the 6 kilometers. If the links coming out of the splitter are different lengths, then be sure to have enough transmitting power to reach the receiver with the longest link. Those with shorter links can be attenuated to lower the signal to a level the receiver can use. To be sure the receiver is in the correct range, use the Receive Test Point using a high impedance multimeter. The optimum range for the FOCN is 0.5VDC to 0.9VDC (approx. -3dBm to -0.5dBm). Operation down to -8dBm is feasible with reduced performance.

If the Fiber run is less than a few kilometers, then the optical signal must be lowered before the system can operate correctly. Failure to lower the signal into the operating range of the receiver may cause an overloaded or distorted picture. The easiest way to lower the signal is to use an optical attenuator.

If the signal getting to the receiver is too low, but the correct power transmitter is being used, please check the following:

- 1: Be sure the fiber connectors are all of the same type. All FOCN units are shipped with SC/APC style connectors. These will be green in color. You can NOT mix green and blue connectors, as the end terminations are different. This can also result in low signal or snowy picture. ST connectors are generally orange, these are for use with Multi Mode, and are not appropriate for broadband use.
- 2: Broadband RF transmitters such as those made by Blonder Tongue require the use of Single Mode fiber. Multi Mode fiber will not work. Attempting to use Multi Mode fiber will result in low signal or snowy picture.

MAINTENANCE INSTRUCTIONS

Cleaning

If the units need to be cleaned, avoid the use of all solvents and use low-pressure clean air to remove loose dirt. Use low-pressure clean air to clear the connectors of any debris. Dirty or scratched connector end faces will greatly reduce the unit's performance. Foam-tipped swabs such as the 2.5mm Mini Foam Swab offered by Fiber Instrument Sales (P/N F1-0005) may be saturated with denatured alcohol* and inserted into the optical port for cleaning. **DO NOT INSERT A DRY SWAB INTO THE OPTICAL PORT AS THIS MAY DAMAGE THE FIBER END FACE.** Many fiber optic installations experience degraded performance due to dirty optical connector end faces. The following procedure should be used to properly clean the optical connector end faces.

Connector Cleaning

Required Cleaning Equipment:

- Kimwipes[®] or any lens-grade, lint-free tissue. The type sold for eyeglasses work quite well.
- Denatured Alcohol.*
 - * NOTE: Use only industrial grade 99% pure isopropyl alcohol. Commercially available isopropyl alcohol is for medicinal use and is diluted with water and a light mineral oil. Industrial grade isopropyl alcohol should be used exclusively.
- 30X Microscope.
- Canned Dry Air.

Directions for Cleaning:

- 1) Fold the tissue twice so it is four layers thick.
- 2) Saturate the tissue with alcohol.
- 3) First clean the sides of the connector ferrule. Place the connector ferrule in the tissue, and apply pressure to the sides of the ferrule. Rotate the ferrule several times to remove all contamination from the ferrule sides.
- 4) Now move to a clean part of the tissue. Be sure it is still saturated with alcohol, and it is still four layers thick. Put the tissue against the end of the connector ferrule. Put your fingernail against the tissue so that it is directly over the ferrule. Now scrape the end of the connector until it squeaks. It will sound like a crystal glass that has been rubbed when it is wet.
- 5) Use the microscope to verify the quality of the cleaning. If it isn't completely clean repeat the steps with a clean tissue.
- 6) Mate the connector immediately! Don't let the connector lie around and collect dust before mating.
- 7) Air can be used to remove lint or loose dust from the port of a transmitter or receiver to be mated with the connector. Never insert any liquid into the ports.

Connector Handling

- 1) **NEVER TOUCH THE FIBER END FACE OF THE CONNECTOR.**
- 2) Connectors not in use should be covered over the ferrule by a plastic dust cap. It is important to note that the inside of the ferrule dust caps contains a sticky gelatinous residue that is the by-product of the making of the dust cap. This residue will remain on the ferrule end after the cap is removed. Therefore it is critical that the ferrule end be cleaned thoroughly BEFORE it is mated to the intended unit.

Notes

Notes

Limited Warranty

Blonder Tongue Laboratories, Inc. (BT) will at its sole option, either repair or replace (with a new or factory reconditioned product, as BT may determine) any product manufactured by BT which proves to be defective in materials or workmanship or fails to meet the specifications which are in effect on the date of shipment or such other specifications as may have been expressly agreed upon in writing (i) for a period of one (1) year from the date of original purchase (or such shorter period of time as may be set forth in the license agreement specific to the particular software being licensed), with respect to iCentral™ (hardware and software) and all other software products (including embedded software) licensed from BT, (ii) for a period of one (1) year from the date of original purchase, with respect to all MegaPort™, IPTV products, and fiber optics receivers, transmitters, couplers and integrated receiver/distribution amplifiers (including TRAILBLAZER™, RETRO-LINX™ and TWIN STAR™ products) as well as for DigiCipher ® satellite receivers, and (iii) for a period of three (3) years from the date of original purchase, with respect to all other BT products. Notwithstanding the foregoing, in some cases, the warranty on certain proprietary sub-assembly modules manufactured by third-party vendors and contained in BT products and on certain private-label products manufactured by third-parties for resale by BT are of shorter duration or otherwise more limited than the standard BT limited warranty. In such cases, BT's warranty with respect to such third-party proprietary sub-assembly modules and private-label products will be limited to the duration and other terms of such third-party vendor's warranty. In addition, certain products, that are not manufactured but are resold by BT, carry the original OEM warranty for such products. The limited warranty set forth in this paragraph does not apply to any product sold by BT, which at the time of sale constituted a Refurbished/Closeout Product.

(b) BT will at its sole option, either repair or replace (with a new or factory-reconditioned product, as BT may determine) any product sold by BT which at the time of sale constituted a refurbished or closeout item ("Refurbished/Closeout Product"), which proves to be defective in materials or workmanship or fails to meet the specifications which are in effect on the date of shipment or such other specifications as may have been expressly agreed upon in writing, for a period of ninety (90) days from the date of original purchase. Notwithstanding the foregoing, in some cases the warranty on third party software and on certain proprietary sub-assembly modules manufactured by third-party vendors and contained in BT products and on certain private-label products manufactured by third-parties for resale by BT are of shorter duration or otherwise more limited than the BT limited warranty for Refurbished/Closeout Products. In such cases, BT's warranty for Refurbished/Closeout Products constituting such third party software, third-party proprietary sub-assembly modules and private-label products will be limited to the duration and other terms of such third-party vendor's warranty. In addition, notwithstanding the foregoing, (i) certain Refurbished/Closeout Products that are not manufactured (but are resold) by BT, carry the original OEM warranty for such products, which may be longer or shorter than the BT limited warranty for Refurbished/Closeout Products. All sales of Refurbished/Closeout Products are final.

To obtain service under this warranty, the defective product, together with a copy of the sales receipt or other satisfactory proof of purchase and a brief description of the defect, must be shipped freight prepaid to: Blonder Tongue Laboratories, Inc., One Jake Brown Road, Old Bridge, New Jersey 08857.

This warranty does not cover damage resulting from (i) use or installation other than in strict accordance with manufacturer's written instructions, (ii) disassembly or repair by someone other than the manufacturer or a manufacturer-authorized repair center, (iii) misuse, misapplication or abuse, (iv) alteration, (v) lack of reasonable care or (vi) wind, ice, snow, rain, lightning, or any other weather conditions or acts of God.

OTHER THAN THE WARRANTIES SET FORTH ABOVE, BT MAKES NO OTHER WARRANTIES OR REPRESENTATIONS OF ANY KIND, EXPRESS OR IMPLIED, AS TO THE CONDITION, DESCRIPTION, FITNESS FOR A PARTICULAR PURPOSE, MERCHANTABILITY, OR AS TO ANY OTHER MATTER, AND SUCH WARRANTIES SUPERSEDE ANY ORAL OR WRITTEN WARRANTIES OR REPRESENTATIONS MADE OR IMPLIED BY BT OR BY ANY OF BT'S EMPLOYEES OR REPRESENTATIVES, OR IN ANY OF BT'S BROCHURES MANUALS, CATALOGS, LITERATURE OR OTHER MATERIALS. IN ALL CASES, BUYER'S SOLE AND EXCLUSIVE REMEDY AND BT'S SOLE OBLIGATION FOR ANY BREACH OF THE WARRANTIES CONTAINED HEREIN SHALL BE LIMITED TO THE REPAIR OR REPLACEMENT OF THE DEFECTIVE PRODUCT F.O.B. SHIPPING POINT, AS BT IN ITS SOLE DISCRETION SHALL DETERMINE. BT SHALL IN NO EVENT AND UNDER NO CIRCUMSTANCES BE LIABLE OR RESPONSIBLE FOR ANY CONSEQUENTIAL, INDIRECT, INCIDENTAL, PUNITIVE, DIRECT OR SPECIAL DAMAGES BASED UPON BREACH OF WARRANTY, BREACH OF CONTRACT, NEGLIGENCE, STRICT TORT LIABILITY OR OTHERWISE OR ANY OTHER LEGAL THEORY, ARISING DIRECTLY OR INDIRECTLY FROM THE SALE, USE, INSTALLATION OR FAILURE OF ANY PRODUCT ACQUIRED BY BUYER FROM BT.

All claims for shortages, defects, and non-conforming goods must be made by the customer in writing within five (5) days of receipt of merchandise, which writing shall state with particularity all material facts concerning the claim then known to the customer. Upon any such claim, the customer shall hold the goods complained of intact and duly protected, for a period of up to sixty (60) days. Upon the request of BT, the customer shall ship such allegedly non-conforming or defective goods, freight prepaid to BT for examination by BT's inspection department and verification of the defect. BT, at its option, will either repair, replace or issue a credit for products determined to be defective. BT's liability and responsibility for defective products is specifically limited to the defective item or to credit towards the original billing. All such replacements by BT shall be made free of charge f.o.b. the delivery point called for in the original order. Products for which replacement has been made under the provisions of this clause shall become the property of BT. Under no circumstances are products to be returned to BT without BT's prior written authorization. BT reserves the right to scrap any unauthorized returns on a no-credit basis. Any actions for breach of a contract of sale between BT and a customer must be commenced by the customer within thirteen (13) months after the cause of action has accrued. A copy of BT's standard terms and conditions of sale, including the limited warranty, is available from BT upon request. Copies of the limited warranties covering third-party proprietary sub-assembly modules and private-label products manufactured by third-parties are also available from BT on request. DigiCipher ® is a registered trademark of Motorola Corp. (Rev 0509)



**BLONDER
TONGUE**
LABORATORIES, INC.

One Jake Brown Road
Old Bridge, NJ 08857-1000 USA
(800) 523-6049 • (732) 679-4000 • FAX: (732) 679-4353
www.blondertongue.com