

# Robo Ruggedized PTZ

## Instruction Manual Version 3.1

---



Please read this manual carefully before installation and operation of the product.

# Table of Contents

<b>1.</b>	<b>INTRODUCTION</b>	<b>4</b>
<b>2.</b>	<b>SAFETY WARNING</b>	<b>5</b>
<b>3.</b>	<b>PACKING LIST</b>	<b>6</b>
<b>4.</b>	<b>MOUNTING</b>	<b>8</b>
	• Mounting Options (UK Column Mounting)	
	• Offset Mounting	
	• Changing the Wiper	
	• 14 Pin Cable Connection	
<b>5.</b>	<b>TELEMETRY CONTROL</b>	<b>11</b>
	• On-Board Protocols	
	• DIL (Dual In-Line) Switches	
	• Protocol Settings	
	• Baud Rate Settings	
	• RS485 Address Settings	
	• RS485 Termination	
	• Keyboard Operation	
<b>6.</b>	<b>SETUP MENU OVERVIEW</b>	<b>16</b>
	<b>MAIN MENU</b>	<b>21</b>
	• <b>PAN TILT SET</b>	
	• ID DISPLAY	
	• P/T DISPLAY	
	• CAMERA NAME	
	• MANUAL SPEED	
	• PROPO. P/T	
	• DIGITAL FLIP	
	• IMAGE HOLD	
	• INSTALLATION	
	• AUTO REFRESH	
	• EXIT	

- **CAMERA SET**

- WDR
- MOTION DET
- ATW
- FOCUS / ZOOM
- AE
- DAY & NIGHT
- SPECIAL
- EXIT

- **AUTOSEQ SET**

- PRESET
- TOUR
- SCAN
- PATTERN
- AUTO PAN
- AUTO RUN
- HOME POSITION
- EXIT

- **ZONE SET**

- AREA SEL
- AREA DEFINE
- AREA COLOUR
- AREA NEW SET
- HEIGHT EDIT
- WIDTH EDIT
- PAN ANGLE
- TILT ANGLE
- EXIT

- **ALARM SET**

- ALARM DISPLAY
- ALARM IN
- ALARM OUT
- TIME OUT
- EXIT

- **WIPER SET**

- WIPER RUN
- EXIT

- **INITIALISE SET**

- POWER ON RESET
- PAN / TILT INIT
- CAMERA INIT
- AUTO SEQ INIT
- PRIVACY ZONE INIT
- FACTORY INIT
- EXIT

<b>7.</b>	<b>SPECIFICATION</b>	<b>46</b>
<b>8.</b>	<b>DIMENSIONS</b>	<b>47</b>

## 1. Introduction

This unit is designed to provide clear video images, even in extreme conditions. A robust mechanism, allied with the latest technology, offers excellent auto-focus during PTZ operations. Exact location control, following preset programmed operations, high-speed zoom and auto focus capabilities for shooting moving objects, are just some of this camera's features. The flat window and over 700TVL provide a vivid picture quality, and the zoom interlocked Target IR LED technology gives outstanding performance when monitoring night time environments; it also features 512x Super WDR.

Long-distance objects are easily distinguished with the outstanding performance of the Sony 36x Optical and 32x Digital Zoom; total Power Zoom capability of 1152x. The IR models have x2 High Intensity "Target" Infra-Red LED's that fully integrate with the camera's 36x zoom module, giving extremely detailed images at night time. During a zoom operation the LED coverage changes proportionately with the zoom of the camera. The angle of LED coverage goes from 60 degrees at its widest part to 6 degree at its narrowest. This minimises light pollution and eliminates IR illumination of unimportant areas. Medium to long range targets become the true focal point for the camera lens and the LED's. There is also a built-in and adjustable de-fog function which enhances images in foggy or misty environments.

## Features

- 1/4" Sony Super HAD CCD
- Powerful Night Vision - up to 100m in Ideal Conditions – IR Models Only
- Target IR LED's (IR angle 6~60 degrees; synchronised with the optical zoom ratio) – **IR Models Only**
- Embedded and Adjustable Defog and Image Enhancer
- 512x Wide Dynamic Range (WDR)
- 2D and 3D DNR (Digital Noise Reduction)
- 36x Optical Zoom and 32x Digital Zoom – total 1152x Power Zoom capability
- 360 Degree Endless Panning
- Wide Tilt Range of -25~205 Degrees
- True Day/Night with IR Cut Filter
- 128 Presets and Tour Function
- DIS (Digital Image Stabiliser)
- Integrated Heater/Blower for -40°C and +60°C Operation
- High Performance & Low-Noise Wiper, with Anti-Abrasion Soft Silicon Rubber
- Hydrophobic Surface Coated Flat Glass
- Anti-Corrosion, Anti-Saltwater Powder Coated Surface Finish
- Auto Digital Flip
- 8 Privacy Zones
- IP68 Rated
- Upright and Pendant Installation Mounting Option.



## 2. Safety Warning

\* The purpose of this information is to ensure proper use of this product and to prevent danger and damage to persons and property. Please observe all precautions.

\* The precautions are divided into “Warnings” and “Cautions” as distinguished by the symbols shown below;

**Warning:** Ignoring these warnings may result in death or serious injury.

**Caution:** Ignoring these cautions may result in injury or damage to property.

	
<b>Caution:</b> Instructions alert you to the potential risk of injury or damage to property	<b>Warning:</b> Instructions alert you to the potential risk of death or serious injury

### Warning

1. Only use the standard Power Adapter ) Using any other adapter could cause fire, electrical shock, or damage to the product, and invalidate the warranty.
2. Before connecting the power supply, and signal wires, make sure the external connections are isolated. Connect the alarm signal wires to the alarm terminals, the communication wires to the terminal block and the AC adapter to the AC power input receptacle (incorrectly connecting the power supply may cause fire, electrical shock, or damage to the product).
3. Do not connect multiple cameras to a single Power Adapter. Exceeding the adapter’s current capacity can cause abnormal heat generation or fire.
4. Securely plug, or connect, the power cord into the power receptacle. An insecure or loose connection may cause a fire.
5. When installing the camera on a wall or ceiling etc. fasten it securely using suitable anchor bolts and/or fixings. An unsecured camera could fall and cause serious personal injury, or even a fatality.
6. Do not place conductive objects (e.g. screwdrivers, coins or other metal objects) inside any part of the camera. Doing so may cause personal injury, a fire or an electrical shock.
7. Do not install the unit in humid or dusty locations. Doing so may cause a fire or electrical shock.
8. If any unusual smells or smoke come from the unit, stop using the product immediately, disconnect the camera from the power source and contact your distributor.
9. If this product fails to operate normally, contact your distributor. Never disassemble or modify this product in any way.
10. Always clean the camera with water and wipe the surface dry with a soft lint free cloth. Never use detergents or chemical agents on the product, as this may result in discolouration of the painted surface or cause damage to the finish.

## Caution

1. Do not drop objects on the product, or apply strong shocks to it. Keep away from locations subject to excessive vibration or magnetic interference.
2. Do not install in locations subject to a continual high temperature range (over 50°C), continual low temperature (below -40°C) or high humidity.
3. Avoid locations which are exposed to direct sunlight, radiation or near heat sources such as heaters or radiators.
4. If an already installed product needs to be relocated, make sure the power is turned off before it is moved.
5. Always try and install in a well-ventilated environment.
6. Make sure the camera is adequately protected against lightning strikes by using a suitably rated surge protector, which must be locally grounded. Failure to do so could irreparably damage the camera, and any attached communication and telemetry equipment.

## 3. Packing List



Wide Dynamic 36x Zoom  
Rugged PTZ Camera x1



Instruction Manual x1

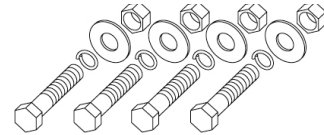

Hex Bolt / Nylon Nut / Spring  
Washer / Plate Washer  
-M8 x 35 (SUS) x4

### Option (UK Column Mounting)

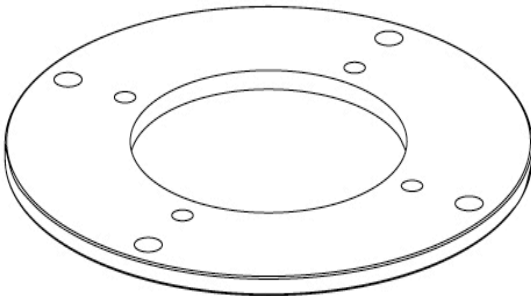

Adapter Plate

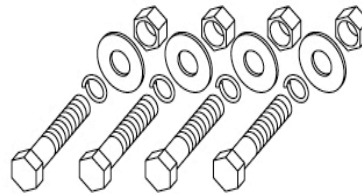

Hex Bolt / Nylon Nut / Spring Washer /  
Plate Washer

## Instruction

Please put the supplied anticorrosive silicon grease over the edge area on each screw hole of the PCD adapter plate before using M8 Hex Bolts.

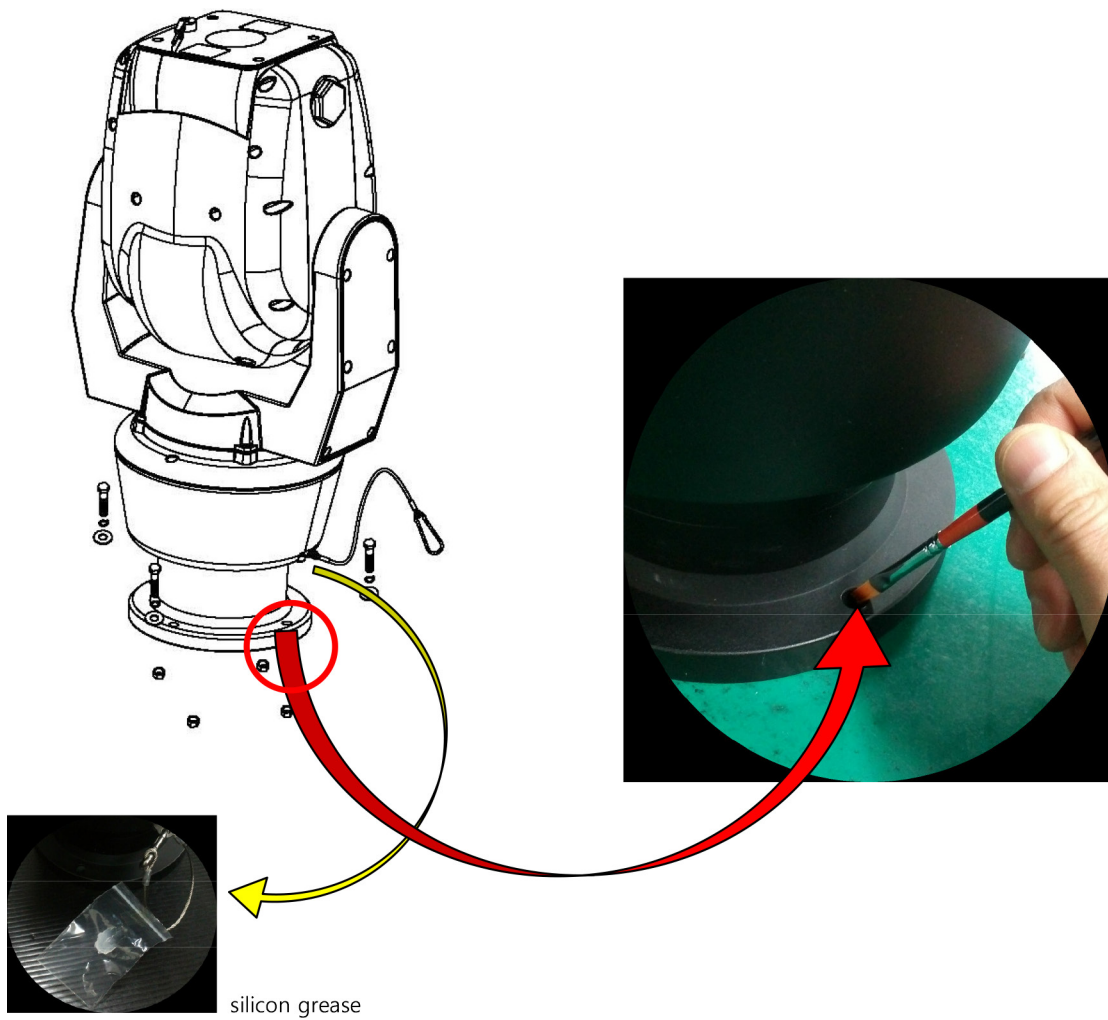

## 4. Mounting

This unit is designed for installation in the upright or inverted position. It is a heavy duty mechanism and requires a secure and safe installation surface, and we recommend installers use brackets, towers and columns which comply with the industrial standard - 4" (142.0mm) PCD.

Cable connections are made using the camera base.

The camera base is supplied with a 4" (142.0mm) PCD adapter plate and connects to a bracket or tower using three M8 Hex Bolts, s/w, p/w and Nylon Nuts, with Spring and Plate Washers.

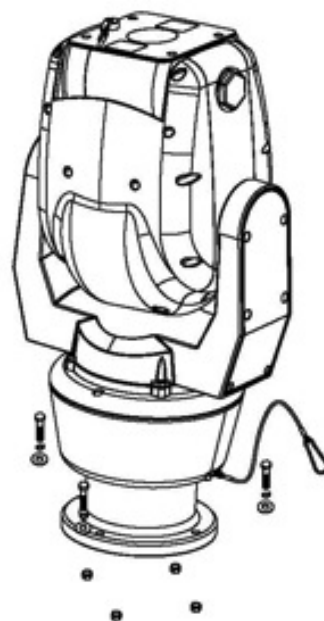

- **Mounting (Locally procured )**

The camera is supplied with an adapter, 4" (101.6mm) PCD, which complies with the uniform standard for UK Pole or Column camera mounts.

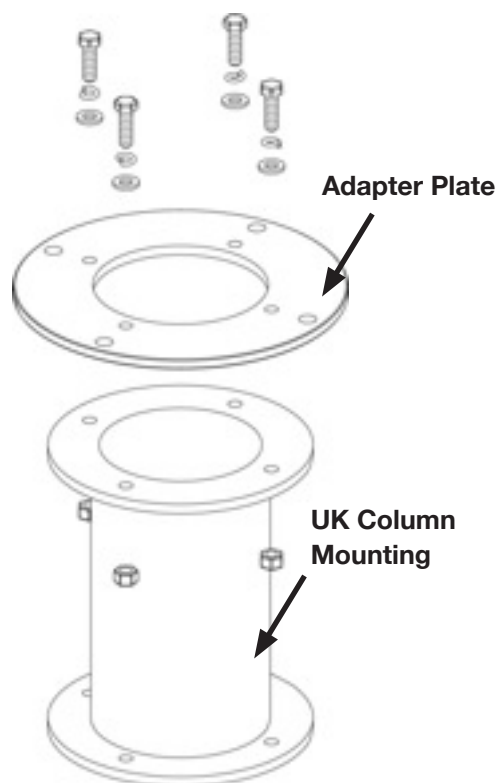





A Safety Wire, made from stainless steel, is provided for securing the Robo PTZ during installation and maintenance visits; to prevent damage and injury.

During installation and maintenance visits, please make sure the Safety Wire is firmly connected to a secure fixing.

## • Offset Mounting

When an installation requires the camera module to be tilted down – to obtain an angle of view immediately below Robo PTZ – the following procedure **MUST** be followed. We recommend using a local test monitor to check the viewing angle before finally fixing the module into position.

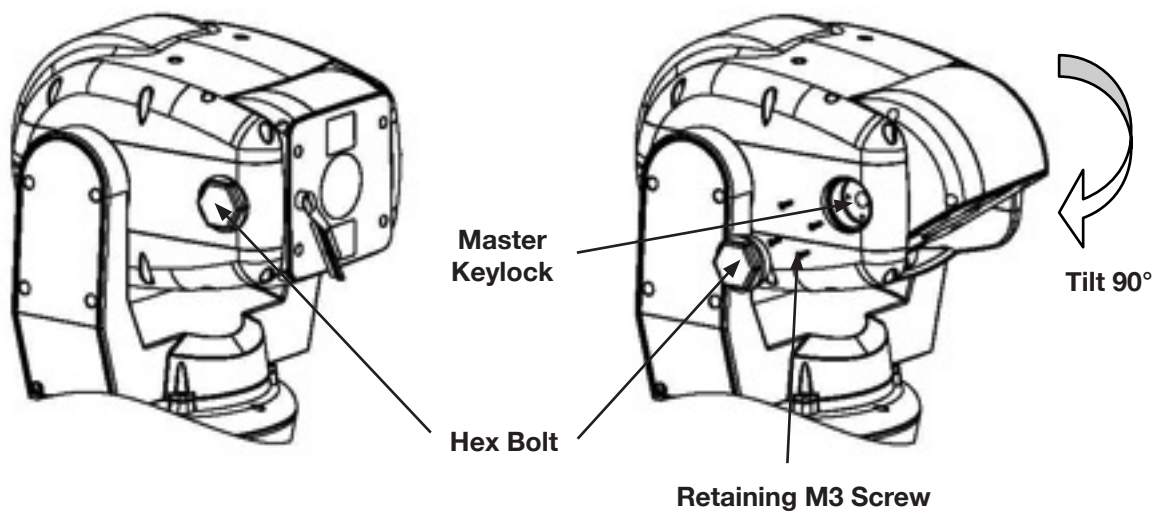

Undo the Hex Bolt, using a 36mm Spanner, when the camera is in 0° Tilt.

Then, using a screwdriver, undo the 4 x M3 Retaining Screws.

**Completely remove the silver Master Keylock Cog – failure to do so will result in irreparable damage to the camera head.**

After tilting down the camera module to the required angle, replace the Master Keylock Cog (this is keyed and only can be located in a unique position), the M3 Retaining Screws and the Hex Bolt. The Torque setting for the Hex Bolt is 0.84Kg/m.



**DO NOT** excessively tighten the Retaining Screws or Hex Bolt.

- **Changing the Wiper**

The Wiper can be removed, changed and replaced by undoing the two retaining screws.

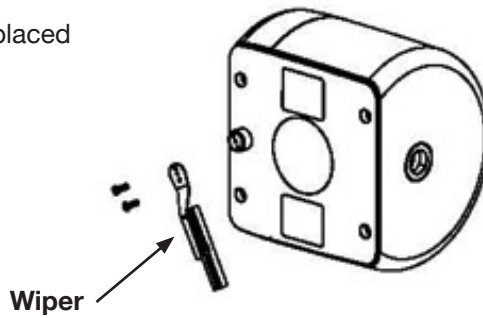

Please keep the window glass clean to maintain clear images.

- **14-Pin Cable Connection**

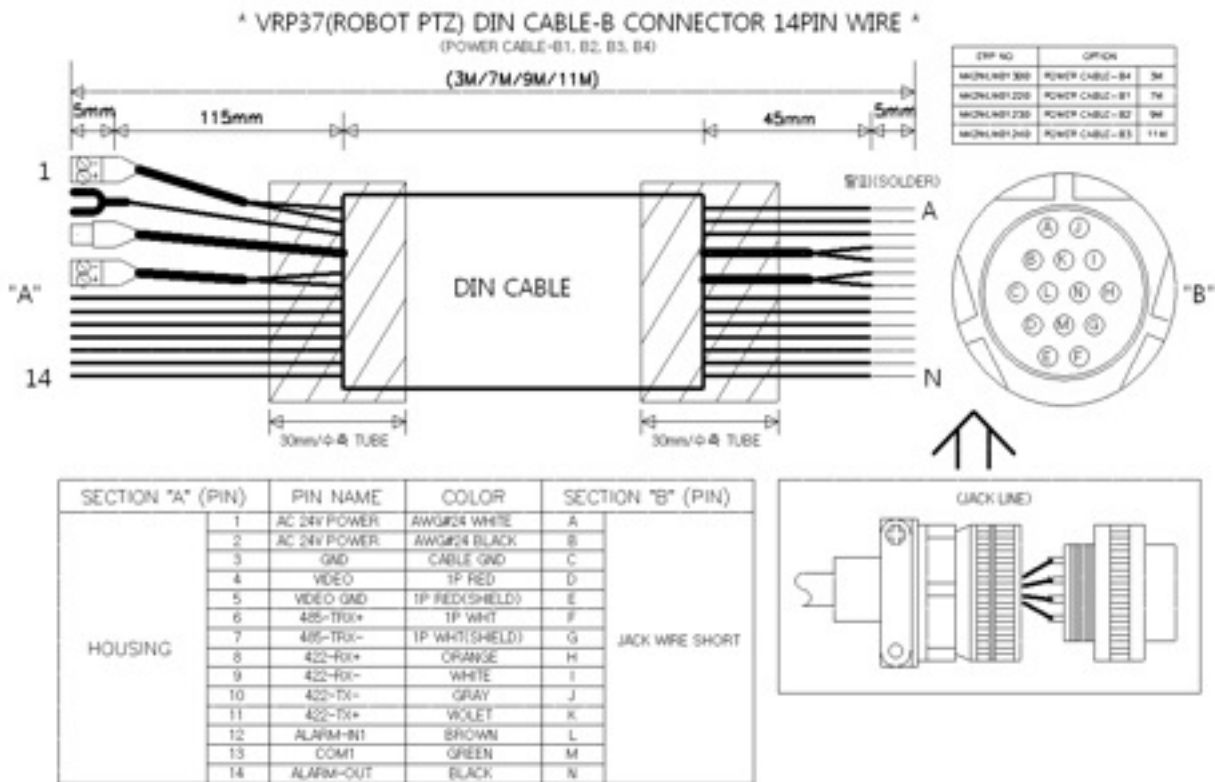

## 5. Telemetry Control

This unit is designed with a range of diverse Telemetry Control systems, based on compatibility with industrial standard protocols. It works by using these integrated protocols directly, or via 3rd party protocol converters.

Telemetry Control is via way of RS485 or Coaxial based video transmission equipment. Some limitation on protocols and/or software changes may not guarantee to take full advantage of all the features from the manufacturer, and may limit features and operation of the Robo PTZ

When the Telemetry Control is based on RS485, the address range is limited to 127.

- **On-Board Protocols**

This unit provides On-Board Protocols, including:

- BBV 422
- Pelco D
- Pelco P

- **DIL (Dual In-Line) Switches**

Two 8-way DIL Switches are contained within a waterproofed cover on the camera body; these are used to select the camera address, communication protocol and baud rate.

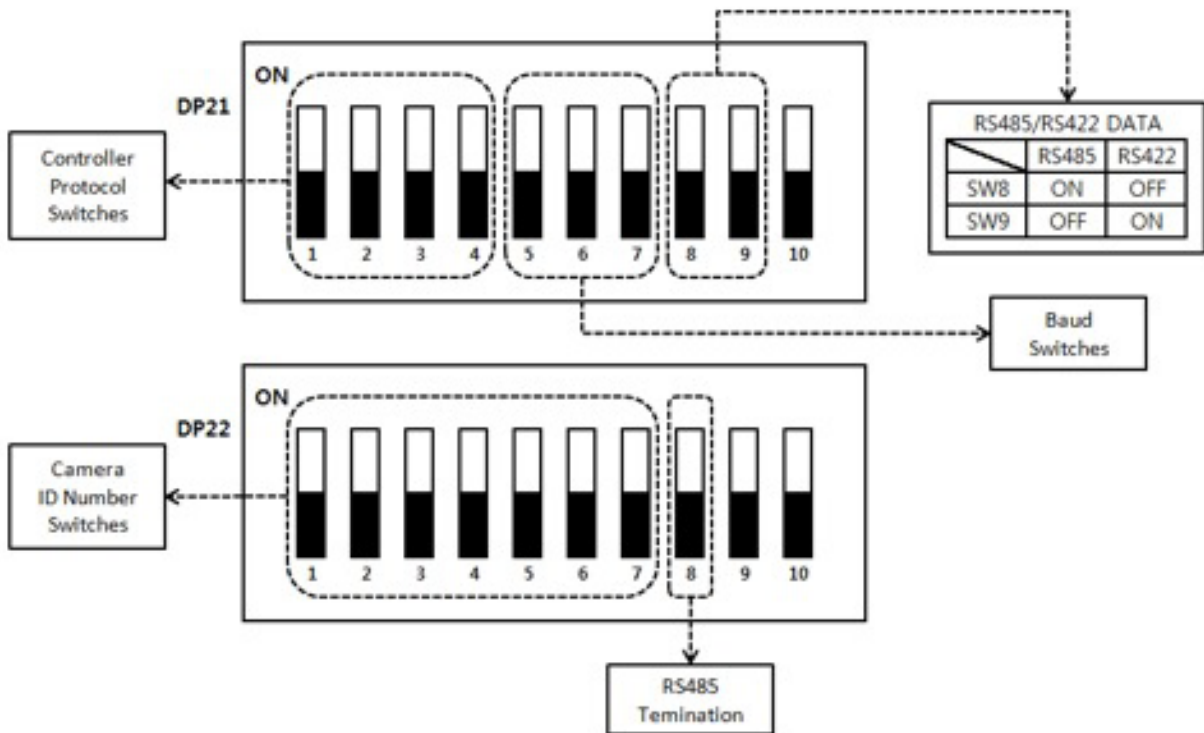
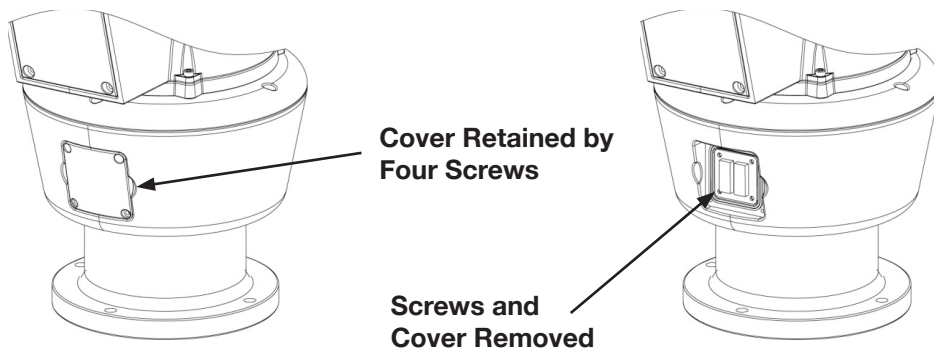

- **Protocol Settings**

Protocol is selected using switches DP21-1, DP21-2, DP21-3 and DP21-4.

The configuration of the Protocol is as follows.

When an installer uses a protocol based Coaxial cable, it isn't using a RS485 Address so you can leave the Address as 0

Description	No	DP21-1	DP21-2	DP21-3	DP21-4	Apply
PELCO-D	0	OFF	OFF	OFF	OFF	OK
PELCO-P	1	ON	OFF	OFF	OFF	OK
BBV	2	OFF	ON	OFF	OFF	OK
VCL	3	ON	ON	OFF	OFF	OK
PANASONIC	4	OFF	OFF	ON	OFF	OK
AD	5	ON	OFF	ON	OFF	OK
HONEYWELL	6	OFF	ON	ON	OFF	OK
SAMSUNG	7	ON	ON	ON	OFF	OK
FVISION	8	OFF	OFF	OFF	ON	OK

- **Baud Rate Settings**

The Baud Rate, communication speed, is selected using switches DP21-5, DP21-6 and DP21-7.

Baud Rate configuration settings are as follows:

Description	Protocol NO.	DP21-5	DP21-6	DP21-7
BAUD_2400	0	OFF	OFF	OFF
BAUD_4800	1	ON	OFF	OFF
BAUD_9600	2	OFF	ON	OFF
BAUD_19200	3	ON	ON	OFF
BAUD_34800	4	OFF	OFF	ON

- **RS485 Address Settings**

ID setting for DP22 switches SW1~SW7    DIP Switch setting 1-ON, 0-OFF

DIP SW	ID	DIP SW	ID	DIP SW	ID
1000000	1	1010100	21	1001010	41
0100000	2	0110100	22	0101010	42
1100000	3	1110100	23	1101010	43
0010000	4	0001100	24	0011010	44
1010000	5	1001100	25	1011010	45
0110000	6	0101100	26	0111010	46
1110000	7	1101100	27	1111010	47
0001000	8	0011100	28	0000110	48
1001000	9	1011100	29	1000110	49
0101000	10	0111100	30	0100110	50
1101000	11	1111100	31	1100110	51
0011000	12	0000010	32	0010110	52
1011000	13	1000010	33	1010110	53
0111000	14	0100010	34	0110110	54
1111000	15	1100010	35	1110110	55
0000100	16	0010010	36	0001110	56
1000100	17	1010010	37	1001110	57
0100100	18	0110010	38	0101110	58
1100100	19	1110010	39	1101110	59
0010100	20	0001010	40	0011110	60
1011110	61	0010101	84	1101011	107
0111110	62	1010101	85	0011011	108
1111110	63	0110101	86	1011011	109
0000001	64	1110101	87	0111011	110
1000001	65	0001101	88	1111011	111
1100001	67	0101101	90	1000111	113
0010001	68	1101101	91	0100111	114
1010001	69	0011101	92	1100111	115
0100001	66	1001101	89	0000111	112
0110001	70	1011101	93	0010111	116
1110001	71	0111101	94	1010111	117
0001001	72	1111101	95	0110111	118
1001001	73	0000011	96	1110111	119
0101001	74	1000011	97	0001111	120
1101001	75	0100011	98	1001111	121
0011001	76	1100011	99	0101111	122

DIP SW	ID	DIP SW	ID	DIP SW	ID
1011001	77	0010011	100	1101111	123
0111001	78	1010011	101	0011111	124
1111001	79	0110011	102	1011111	125
0000101	80	1110011	103	0111111	126
1000101	81	0001011	104	1111111	127
0100101	82	1001011	105		
1100101	83	0101011	106		

- **RS485 Termination**

If Robo PTZ is using RS485 communication, please make sure the Bus is correctly installed and configured to prevent malfunctions. The maximum allowed cable distance is 1200 metres. A Maximum of 32 units can be connected to a cable section.

Any cable type which exceeds the specification of EIA RS485 can be used. The furthest device, by cable length, should be terminated in accordance with the specification. Other devices should remain un-terminated (see Figure 11 below).

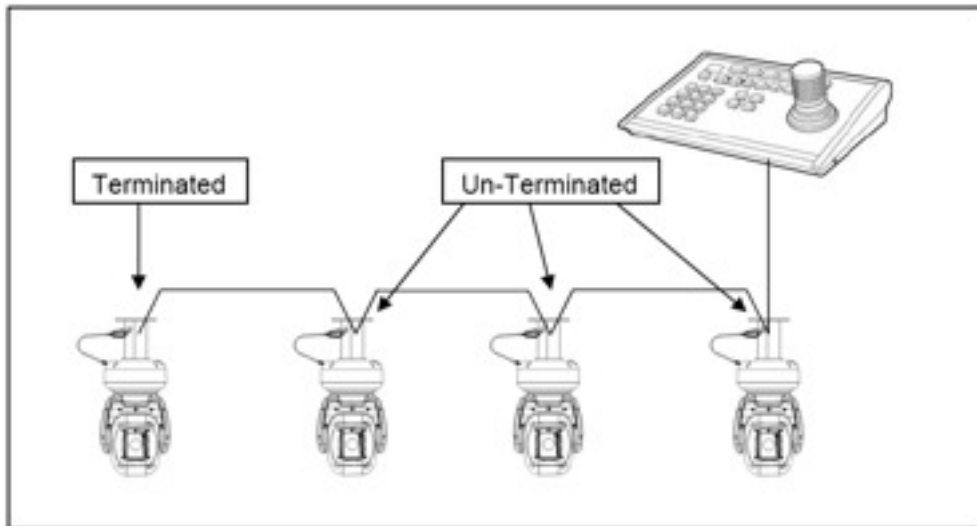

Figure 11

- **Keyboard Operation**

Key Sequences and Joystick movements are executed to closely control the camera and program the Telemetry Control system of Robo PTZ. Examples of these are PRESET and TOUR.

If a Keyboard cannot be used to access and change the camera parameters, most characteristics are accessible through the camera's OSD menu.

**Note** – Changing a Keyboard's Software and/or Protocol can effect alterations to the camera's operability. The Robo PTZ manufacturer absolves itself of responsibility for such modifications.

## 6. Setup Menu Overview

In this chapter, we will look at the overall structure of the Setup Menu and then later look at the function of each menu.

### MAIN MENU

<b>PAN / TILT SET</b>	→	<b>ID DISPLAY</b>	→	<b>ON / OFF</b>
	→	<b>P/T DISPLAY</b>	→	<b>OFF / ON</b>
	→	<b>CAM NAME</b>	→	<b>OFF / ON</b>
	→	<b>MANUAL SPEED</b>	→	<b>10~110° /SEC</b>
	→	<b>PROPO. P/T</b>	→	<b>ON / OFF</b>
	→	<b>DIGITAL FLIP</b>	→	<b>ON / OFF</b>
	→	<b>IMAGE HOLD</b>	→	<b>OFF / ON</b>
	→	<b>INSTALLATION</b>	→	<b>NORMAL / INVERT</b>
	→	<b>AUTO REFRESH</b>	→	<b>5~240</b>
	→	<b>EXIT</b>		

### CAMERA SET

<b>WDR</b>	→	<b>WDR MODE</b>	→	<b>OFF / ON</b>
	→	<b>WDR LEVEL</b>	→	<b>1~7</b>
	→	<b>ATR LEVEL</b>	→	<b>LOW / MID / HIGH</b>
	→	<b>EXIT</b>		
<b>MD</b>	→	<b>MD DEFINE</b>	→	<b>OFF / ON</b>
	→	<b>MD DISPLAY</b>	→	<b>OFF / ON</b>
	→	<b>SENSITIVITY</b>	→	<b>1~25</b>
	→	<b>INTERVAL T</b>	→	<b>1 SECOND ~ 4 MINUTES</b>
	→	<b>AREA START H</b>	→	<b>0~XX</b>
	→	<b>AREA START V</b>	→	<b>0~XX</b>
	→	<b>AREA END H</b>	→	<b>XX~12</b>
	→	<b>AREA END V</b>	→	<b>XX~8</b>
	→	<b>EXIT</b>		

**CAMERA  
SET**

<b>ATW</b>	→	<b>ATW MODE</b>	→	<b>AUTO / ATW / INDOOR / OUTDOOR / ONEPUSH / MANUAL</b>
	→	<b>ONE PUSH TRG</b>	→	<b>SET</b>
	→	<b>MANUAL RED</b>	→	<b>0~255</b>
	→	<b>MANUAL BLUE</b>	→	<b>0~255</b>
	→	<b>EXIT</b>		

<b>FOCUS / ZOOM</b>	→	<b>FOCUS MODE</b>	→	<b>AUTO / ZOOMTG / MANUAL / ZOOM</b>
	→	<b>AF SENSITIVE</b>	→	<b>NORMAL / LOW</b>
	→	<b>DIG ZOOM</b>	→	<b>OFF / ON</b>
	→	<b>ZOOM SPEED</b>	→	<b>1~8</b>
	→	<b>ZOOM RATIO</b>	→	<b>ON / OFF</b>
	→	<b>AF LIMIT &lt;BW&gt;</b>	→	<b>ON / OFF</b>
	→	<b>EXIT</b>		

<b>AE</b>	→	<b>AE MODE</b>	→	<b>AUTO / SHUTTER / MANUAL</b>
	→	<b>IRIS</b>	→	<b>CLOSE~F1.6</b>
	→	<b>GAIN</b>	→	<b>0~15</b>
	→	<b>BRIGHTNESS</b>	→	<b>1~15</b>
	→	<b>SHUTTER</b>	→	<b>1/50~1/100000</b>
	→	<b>SLOW SHUTTER</b>	→	<b>OFF / ON</b>
	→	<b>FLICKERLESS</b>	→	<b>OFF / ON</b>
	→	<b>BLC</b>	→	<b>OFF / ON</b>
	→	<b>L-LUMINANCE</b>	→	<b>OFF / ON</b>
	→	<b>EXIT</b>		



**CAMERA SET**

**DAY & NIGHT**

- **MODE** → **AUTO / DAY / NIGHT**
- **DELAY** → **5~60 SEC.**
- **THRESHOLD** → **1~29**
- **GAP** → **1~5**
- **BURST** → **ON / OFF**
- **IR LED ANGLE** → **AUTO / 60.0,57.0, 55.0, 51.0, 47.0, 40.0, 37.0, 33.0, 28.0, 23.0, 20.0,15.0,10.0,8.0,6.0**
- **EXIT**

**SPECIAL**

- **STABILISER** → **OFF / ON**
- **HR** → **OFF / 1~7**
- **IMAGE FLIP** → **OFF / ON**
- **IMAGE MIRROR** → **OFF / ON**
- **SHARPNESS** → **0~14**
- **2D-DNR** → **AUTO, OFF~15**
- **3D-DNR** → **AUTO, OFF~15**
- **HLC** → **OFF / ON**
- ON**
  - **LEVEL** → **LOW / MID / HIGH**
  - **CLIP LEVEL** → **1~7**
  - **EXIT**
- **DEFOG** → **OFF / AUTO / USER**
- AUTO**
  - **AUTO LEVEL** → **1~10**
  - **EXIT**
- USER**
  - **FOG LEVEL** → **0~15**
  - **FOG GAMMA** → **0~15**
  - **STRENGTH** → **0~64**
  - **UVSTRENGTH** → **0~13**
  - **NOISESUP** → **0~64**
  - **EDGE LEVEL** → **0~15**
  - **EXIT**
- **EXIT**

## CAMERA SET

PRESET	→	PRESET NO	→	1~128
	→	PRESET DEFINE	→	OFF / ON
	→	PRESET NAME	→	OFF / ON
	→	P/T POSITION	→	XXX / XXX
	→	FOCUS IN BW	→	AUTO / ZOOMTG / MANUAL
	→	WDR	→	OFF / ON
	→	ATW	→	SET
	→	EXIT		

TOUR SET	→	TOUR NO	→	1~5
	→	TOUR NO DEF	→	OFF / ON
	→	NAME	→	TOURGROUP 1
	→	TOUR NAME DEF	→	OFF / ON
	→	DWELL TIME	→	1~120
	→	EXIT		

SCAN	→	SCAN NO	→	1~5
	→	SCAN DEFINE	→	OFF / ON
	→	NAME	→	SCANGROUP 1
	→	SCAN NAME DEFINE	→	OFF / ON
	→	PAN START POS	→	180
	→	PAN END POS	→	350
	→	TILT POS	→	45
	→	SCAN SPEED	→	2°, 5°, 10°, 20° /S
	→	EXIT		

PATTERN	→	PATT NUMBER	→	1~2
	→	PATT DEFINE	→	OFF / ON
	→	NAME	→	PATTERN001
	→	PATT NAME DEF	→	OFF / ON
	→	PATT RECORD	→	OFF / ON
	→	PATT SPEED	→	2°, 5°, 10°, 20° /S
	→	EXIT		

## CAMERA SET

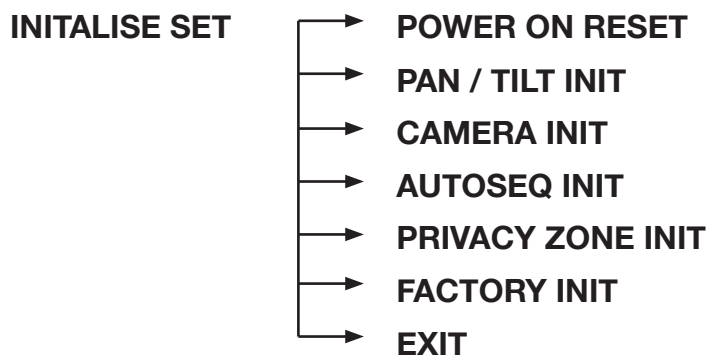
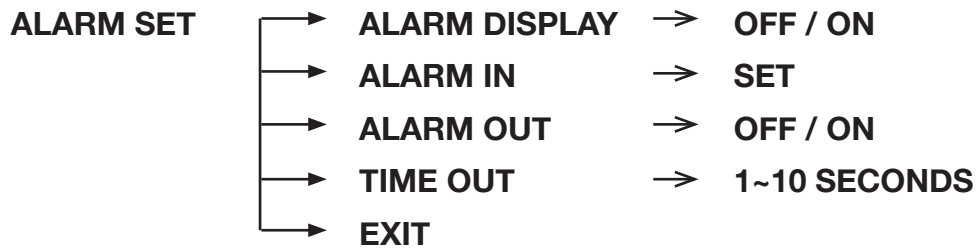
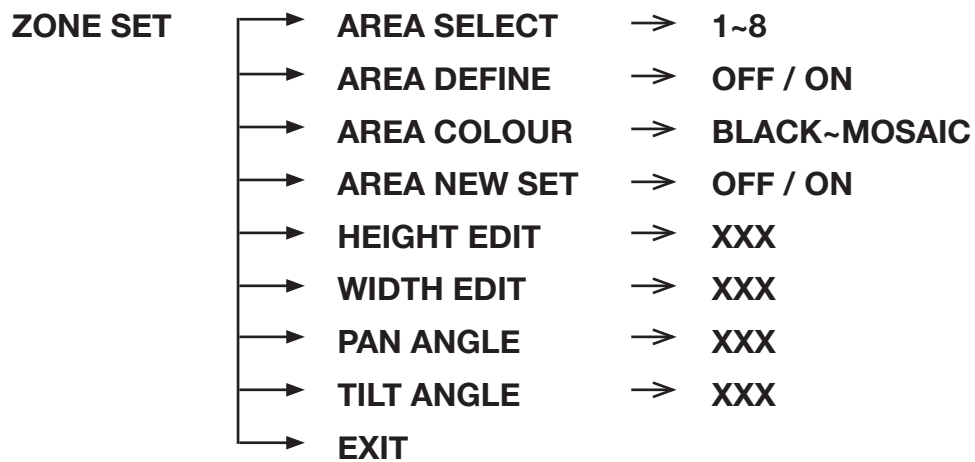
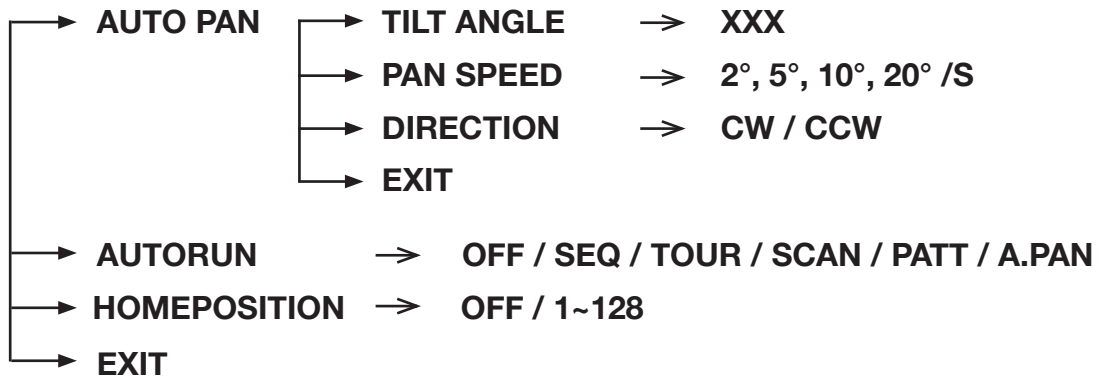

## System information

The diagrams shown in the previous section illustrated the overall structure of the setup menu. In this section, descriptions of the features within the setup menu will enable users of the camera to tailor it to their personal needs.

### MAIN MENU

1. PAN TILT SET
2. CAMERA SET
3. AUTOSEQ SET
4. ZONE SET
5. ALARM SET
6. WIPER SET
7. INITIALISE SET
8. EXIT

### 1. PAN TILT SET

- |                 |                  |
|-----------------|------------------|
| 1. ID DISPLAY   | ON / OFF         |
| 2. P/T DISPLAY  | ON / OFF         |
| 3. CAMERA NAME  | OFF / ON         |
| 4. MANUAL SPEED | 10~110° / SECOND |
| 5. PROPO. P/T   | ON / OFF         |
| 6. DIGITAL FLIP | ON / OFF         |
| 7. IMAGE HOLD   | OFF / ON         |
| 8. INSTALLATION | NORMAL / INVERT  |
| 9. AUTO REFRESH | 5~240            |
| 10. EXIT        |                  |

- Selection: UP, DOWN, LEFT & RIGHT KEYS  
Menu Open: IRIS OPEN KEY  
Menu Close: IRIS CLOSE KEY

- **ID DISPLAY - Camera ID**

OFF: The Camera ID does not appear on the screen.

ON: The Camera ID is displayed on the screen.

To change the position of the camera ID press the IRIS OPEN KEY. When ID is set to ON it's possible to move to the ID DISPLAY Menu, and thereby change the position.

- **P/T DISPLAY**

The PAN/TILT angle is displayed on the bottom right hand side of the screen.

- **CAM NAME**

A maximum of 10 characters can be input. When changing the camera name, press the IRIS OPEN Key after NAME DISPLAY is set to ON.

- **MANUAL SPEED**

Adjustable maximum speed when PAN/ TILT are manually controlled.

- **PROPO. P/T**

Automatically adjusts the PAN/TILT movement speed according to the Zoom magnification level.

OFF: PAN/TILT movement is not automatically controlled.

ON: The PAN/ TILT speed slows down on higher zoom magnification.

- **AUTO FLIP**

OFF: Operates when TILT is below 90°.

ON: Operates when TILT is over 90°.

- **IMAGE HOLD**

When moving to a preset, the screen displays the frozen image of the last displayed preset position.

OFF: Displays the current image.

ON: Displays the frozen image.

**Caution** - FREEZE works during a SEQ, TOUR in AUTORUN MODE.

- **AUTO REFRESH**

Should a PAN/TILT operation overrun its setting value, AUTO REFRESH automatically compensates.

- **INSTALLATION**



**NORMAL:** When the camera is installed upright; as shown left.



**INVERTED:** When the camera is installed pendant style; as shown left.

**Caution** – Tilt Angle: Factory Default (-25 ~ 205 degrees) Tilt angle is limited to -25~90 degrees after setting a zone.

### 1.1.1 DISPLAY

ID location can be changed as follows.

1. Select ON from ID DISPLAY.
2. Press IRIS OPEN KEY.

**MOVE: U/D/L/R**

**EXIT: IRIS CLOSE**

Selection: UP, DOWN, LEFT & RIGHT KEYS  
 Menu Open: IRIS OPEN KEY  
 Menu Close: IRIS CLOSE KEY  
 Press IRIS CLOSE KEY when finished.

### 1.2 CAMERA NAME DISPLAY

**CAMERA NAME MAINCAMERA**

**0123456789ABCDEFGHIJ**

**KLMNOPQRSTUVWXYZ**

**DELETE IRISOPEN**

**POSITION IRISOPEN**

**EXIT**

Selection: UP, DOWN, LEFT & RIGHT KEYS  
 Menu Open: IRIS OPEN KEY  
 Menu Close: IRIS CLOSE KEY

The method for naming a Camera is as follows:

1. Select DELETE and cancel MAINCAMERA by pressing the IRIS OPEN KEY.
2. Move to the desired alphanumeric and press the IRIS OPEN KEY.
3. If you want to change the location of the camera name, select POSITION and press the IRIS OPEN KEY. The method for changing the position of the camera name is the same as in ID DISPLAY.

## 2. CAMERA SET

1. WDR..... SET
2. MOTION DET ..... SET
3. ATW ..... SET
4. FOCUS/ZOOM ..... SET
5. AE ..... SET
6. DAY & NIGHT ..... SET
7. SPECIAL .....SET
8. EXIT

### 2.1 WDR SETUP

1. WDR MODE           OFF / ON
2. WDR LEVEL         1~7
3. ATR LEVEL         LOW/MIDDLE/HIGH
4. EXIT

- **WDR MODE**
  - OFF: WDR doesn't work.
  - ON: WDR is activated.
- **WDR LEVEL**
  - Adjusts the brightness when WDR is activated.
- **ATR LEVEL**
  - Adjusts the contrast in dark areas.

## 2.2 MOTION DETECTION

1. MD DEFINE	OFF / ON
2. MD DISPLAY	OFF / ON
3. SENSITIVITY	1~25
4. INTERVAL T	1 SEC ~ 4 MINUTES
5. AREA START H	0~XX
6. AREA START V	0~XX
7. AREA END H	XX~12
8. AREA END V	XX~8
9. EXIT	

- **MD DEFINE**  
When DEFINE is ON, MD is activated.
- **MD DISPLAY**  
If MD DISPLAY is set to ON, "MOTION" appears on the bottom right hand side of the screen.  
Motion Detection doesn't work when the OSD MENU is activated.
- **SENSITIVITY**  
The Motion Detection sensitivity level is adjustable.  
As the sensitivity level increases the possibility of false activations also increases.
- **INTERVAL T**  
MD is re-activated, according to the set time, after motion has been detected.
- **AREA START H, AREA START V**  
Set a start area for Motion Detection.
- **AREA END H, AREA END V**  
Set an end area for Motion Detection.

### Caution

1. Motion Detection doesn't work in SCAN & PATTERN settings.
2. When using MD, the DWELL TIME should be a minimum of 3 seconds in TOUR settings.
3. Do not set MD if an unstable light source is present e.g. flickering light.
4. Instant changes in light sources may cause false activations e.g. turning lights on or off.
5. This MD function is not intended for fire or antitheft protection and the manufacturer frees itself from any responsibility should it malfunction.



## 2.3 ATW

1. ATW MODE	AUTO-MANUAL
2. ONE PUSH TRG	SET
3. MANUAL RED	0 ~ 255
4. MANUAL BLUE	0 ~ 255
5. EXIT	

Menu Shift : UP, DOWN, LEFT & RIGHT KEYS

Menu Open: IRIS OPEN KEY

Menu Close: IRIS CLOSE KEY

A White Balance setting must be specified and be appropriate for the ambient lighting conditions.

- **ATW MODE AUTO**

White Balance is automatically compensated.

- **ATW MODE ⇔ ATW**

White Balance is automatically compensated when the colour temperature range is 2500°K~9500°K.

- **ATW MODE ⇔ OUTDOOR**

White Balance is optimised for an outdoor environment.

- **ATW MODE ⇔ INDOOR**

White Balance is optimised for an indoor environment.

- **ATW MODE ⇔ ONE PUSH**

White Balance is optimised for the current lighting conditions. If the lighting conditions change, the White Balance should be readjusted. It operates by pressing the IRIS OPEN KEY when SET is on.

- **ATW MODE ⇔ MANUAL**

White Balance is manually adjustable using the RED and BLUE gain controls.

## 2.4 FOCUS/ZOOM

1. FOCUS MODE	AUTO/ZOOMMTG/MANUAL
2. AF SENSITIVE	NORMAL/LOW
3. DIG ZOOM	OFF / ON
4. ZOOM SPEED	1~8
5. ZOOM RATIO	ON / OFF
6. AF LIMIT BW	ON / OFF
7. EXIT	7. EXIT

- **FOCUS MODE**

AUTO

FOCUS is adjusted automatically.

MANUAL

FOCUS is adjustable manually.

ZOOMTG

Whenever ZOOM changes, the FOCUS also changes.

- **AF SENSITIVE**

NORMAL

Focus is adjusted normally.

LOW

Drop the Auto Focus sensitivity to reduce the number of AF operations.

- **DIG ZOOM**

Digital Zoom activates at the maximum level of the Optical Zoom; if the user keeps pushing the “Tele” button.

- **ZOOM SPEED**

Adjusts the zoom tracking speed.

- **ZOOM RATIO**

Displays the zoom ratio on the top right hand side of the screen.

- **AF LIMIT BW** (limited operation of Auto Focus)

The auto-focus function may not operate normally under the following conditions;

When the background illumination is too low, or too high.

While Slow-Shutter is in operation.

If the Zoom level is set too high.

If a long distance object and a close distance object appear together within a monitoring area.

If there is no contrast in the scene i.e. looking at the sky or a wall.

If the camera is pointed toward a thin horizontal line.

Auto Focus focuses on an object in the centre of the screen; objects around the screen edges may not be properly in focus.

**If the IR LED's are ON and the Zoom Ratio is over 20x, the focus mode will be set to manual, regardless of the focus mode settings, in order to stabilise the focus.**

OFF: AF operates with the FOCUS MODE set in the FOCUS/ZOOM MENU on the OSD

ON: This function is useful when IR LED's are ON and Zoom Ratio goes over 20x. FOCUS MODE changes to MANUAL in this condition.

**Caution**

This function holds good when "TOUR, SEQ" is "ON" also.

If AF LIMIT BW is "ON" when IR is activated, AF will be operated as MANUAL FOCUS even if FOCUS MODE under PRESET is set to "AUTO".

## 2.5 AE

1. AE MODE	AUTO/SHUTTER/MANUAL
2. IRIS	CLOSE ~F1.6
3. GAIN	0 ~ 15
4. BRIGHTNESS	1 ~ 15
5. SHUTTER	1/50 ~ 1/100000
6. SLOW SHUTTER	OFF / ON
7. FLICKERLESS	OFF / ON
8. BLC	OFF / ON
9. L-LUMINANCE	OFF / ON
10. EXIT	

- **AE MODE**

AUTO

IRIS and GAIN are controlled automatically. Shutter speed is fixed at 1/50sec (PAL).

SHUTTER

IRIS and GAIN are controlled automatically. Shutter speed can be adjusted manually.

In order to suppress FLICKER, user can set a shutter speed of 1/100sec (PAL).

MANUAL

Users can control the IRIS, GAIN and SHUTTER manually.

- **BRIGHTNESS**

Adjust the brightness used for AE MODE.

- **SHUTTER**

When capturing fast moving subjects, or under low light conditions, users can adjust the shutter speed up or down to get improved image quality.

- **SLOW SHUTTER**

When AE MODE is AUTO and the brightness is decreased, shutter speed is set automatically

OFF (AUTO)

Under low light conditions, shutter speed is automatically controlled according to the brightness of the scene.

ON (MANUAL)

Under low light conditions, shutter speed is controlled according to a set point.

- **BLC**

This function is useful if the subject shows dark against a bright background.

- **FLICKERLESS**

When FLICKERLESS is ON, in order to suppress a FLICKER, the shutter speed is set to 1/100sec (PAL).

- **L-LUMINANCE**

The L-Luminance function makes the entire image brighter. When this function is ON the visibility of the image increases, but as it makes scenes brighter it may also look out of focus.

## 2.6 DAY & NIGHT

1. MODE	AUTO / COLOUR / BW
2. DELAY	5~60 SECONDS
3. THRESHOLD	1~29
4. GAP	1~5
5. BURST	ON / OFF
6. IR LED ANGLE	AUTO / 60.0°~6.0°
7. EXIT	

- **MODE**

AUTO ⇨ Automatically turns to Colour during daytime and B/W at night.

COLOR ⇨ Fixed in Colour mode. IR's are OFF.

BW ⇨ Fixed in BW mode. IR's are ON.

- **DELAY**

Set the switching time from B/W to Colour and from Colour to B/W; necessary for stabilisation.

- **THRESHOLD**

AGC level in Day & Night mode for turning from Colour to B/W. A higher threshold value makes an earlier change from Day to Night at lower AGC levels (i.e. In brighter conditions).

- **GAP**

The gap level when switching between "Colour to B/W mode" and "B/W to Colour mode".

- **BURST**

Output the BURST signal when switching to B/W mode.

- **IR LED ANGLE**

AUTO ⇨ IR LED ANGLE is controlled automatically according to the ZOOM ratio.

60.0 ⇨ IR LED ANGLE is fixed at 60 degrees.

6.0 ⇨ IR LED ANGLE is fixed at 6.0 degrees. This is useful for monitoring an object in the far distance – must be more than 30 metres away.

### Caution

If users set the IR LED ANGLE at 60/6, the IR LED ANGLE is fixed at a set point when AUTO RUN is working; only used on models with integral IR LED's.

## 2.7 SPECIAL

1. STABILISER	OFF / ON
2. HR	OFF / 1~7
3. IMAGE FLIP	OFF / ON
4. IMAGE MIRROR	OFF / ON
5. SHARPNESS	0~14
6. 2D-DNR	AUTO / OFF~15
7. 3D-DNR	AUTO / OFF~15
8. HLC	OFF / ON
9. DE-FOG	OFF / AUTO / USER
10. EXIT	

- **STABILISER**

ON ⇒ Set to “ON” to mitigate vibrations when the camera is installed in an unstable environment - such as, mounted on a pole which is subject to movement.

- **HR**

Horizontal resolution in Colour mode is 700 TV Lines. Users can increase the HR up to 750TVL - by adjusting the level in BW mode.

But, if the level is set too high in B/W mode, it can make create image noise and/or edge distortion.

- **IMAGE FLIP**

The image is flipped vertically.

- **IMAGE MIRROR**

The image is flipped horizontally.

- **SHARPNESS**

Overall sharpness on the screen is adjustable.

- **2D-DNR/3D-DNR (Digital Noise Reduction)**

Reduces image noise in low light conditions. Lowering the DNR level reduces noise in low light conditions, but low levels of DNR can also cause ghosting.

- **HLC**  
 Highlight Compensation cuts out strong light sources, such as car headlights, in order to recognise licence plates or subjects in the entrances to garages or petrol stations.  
 LEVEL: Adjusts the HLC brightness.  
 CLIP LEVEL: Adjusts the HLC Threshold.
- **DE-FOG**  
 OFF : Disable DE-FOG.  
 AUTO: Automatically start the DE-FOG function.  
 USER : USER Setting.

### 2.7.1 DEFOG AUTO SETUP

- |               |      |
|---------------|------|
| 1. AUTO LEVEL | 0~10 |
| 2. EXIT       |      |

The higher the value set for the AUTO LEVEL DEFOG function, the greater the sensitivity.

### 2.7.2 DEFOG DEFOG USER SETUP

- |                |      |
|----------------|------|
| 1. FOG LEVEL   | 0~15 |
| 2. FOG GAMMA   | 0~15 |
| 3. STRENGTH    | 0~64 |
| 4. UV STRENGTH | 0~13 |
| 5. NOISE SUP   | 0~64 |
| 6. EDGE LEVEL  | 0~64 |
| 7. EXIT        |      |

- **FOG LEVEL**  
 Fog Density
- **FOG GAMMA**  
 The adjustable numeric value for contrast level control
- **STRENGTH**  
 If this value is high, bright parts of the image get darker and dark parts get brighter

- **UV STRENGTH**

Only use if the STRENGTH option is set - adjusts the colour levels

- **NOISE SUP**

Decreases noise in low illumination

- **EDGE LEVEL**

Improves image definition

**Caution**

1. If DE-FOG is set to AUTO and the camera switches to B/W mode DE-FOG is turned OFF.
2. If the camera switches to B/W in MANUAL mode DE-FOG remains switched ON.

### 3. AUTOSEQ SET

1. PRESET	SET
2. TOUR	SET
3. SCAN	SET
4. PATTERN	SET
5. AUTO PAN	SET
6. AUTO RUN	OFF / SEQ / TOUR / SCAN / PATT / PAN / A.PAN
7. HOME POSITION	OFF / 1~128
8. EXIT	

Menu Shift: UP, DOWN, LEFT & RIGHT KEYS

Menu Open: IRIS OPEN KEY

Menu Close: IRIS CLOSE KEY

- **PRESET**

Locations for the PAN/TILT and ZOOM functions can be programmed. In an ALARM or TOUR operation, the camera moves to the programmed preset.

- **SEQ**

The programmed PRESETS are executed sequentially from the lowest number.

- **TOUR**

PRESET works in GROUP. Up to 5 Presets per Group can be registered and up to 5 Groups can be operated.



- **SCAN**  
PAN moves from the start point to the end point and up to 5 Scans can be set up.
- **PATTERN**  
The operational path of PAN/TILT actions is saved and PATTERN plays and repeats these PAN/TITL actions.
- **AUTO PAN**  
Continually PANs.
- **AUTORUN**  
OFF: The camera is in a Standby condition.  
SEQ, TOUR, SCAN, PATT, A.PAN: Are executed automatically after the user exits the OSD MENU.
- **HOMEPOSITION**  
If there is any loss of power the camera goes to this programmed Preset.  
If AUTORUN is set, the camera does not go to the programmed Preset.

### 3.1 PRESET

This function, after programming, moves the camera to a designated position.

1. PRESET NO	1~128
2. PRESET DEFINE	OFF / <ON>
3. PRESET NAME	OFF / <ON>
4. P/T POSITION	XXX / YYY
5. FOCUS IN BW	AUTO / ZOOMTG / MANUAL
6. WDR	OFF / ON
7. ATW	SET
8. EXIT	

Menu Shift: UP, DOWN, LEFT & RIGHT KEYS

Menu Open: IRIS OPEN KEY

Menu Close: IRIS CLOSE KEY

- **PRESET NO**

A total of 128 presets can be set up.

Changing the PRESET NO is achieved by using the LEFT and RIGHT keys.

- **PRESET DEFINE**

OFF: PRESET doesn't work

ON: Applicable PRESET is useable.

Changing the location for PAN/TILT/ZOOM in PRESET is as follows.

1. After PRESET DEFINE is changed from OFF to ON, press the IRIS OPEN KEY
2. Use PAN and TILT to move to the desired location.

<b>PRESET NAME</b>	<b>PRESET0001</b>
<b>PAN</b>	<b>XXX</b>
<b>TILT</b>	<b>XXX</b>
<b>ZOOM</b>	<b>TELE / WIDE</b>
<b>EXIT</b>	<b>IRIS CLOSE</b>

3. To ZOOM in on the location, use the TELE or WIDE button on the controller.

4. Finalise the PAN, TILT and ZOOM settings by pressing the IRIS CLOSE KEY.

**Tip: Shortcut**

To change focus mode in 'Preset' setting use the shortcut keys shown below.

67+GO PRESET: AUTO

68+GO PRESET: MANUAL

- **PRESET NAME**

OFF ⇒ When using a PRESET, the PRESET name is not displayed on the screen.

ON ⇒ When using a PRESET, the PRESET name is displayed on the screen.

Default for PRESET name is PRESET001 and the editing method is as follows:

1. After changing a PRESET NAME from OFF to ON press the IRIS OPEN KEY.
2. Editing a PRESET NAME is the same as shown in section "1.3 CAMERA NAME DISPLAY".

- **FOCUS IN BW**

Focus is adjusted as set in the FOCUS/ZOOM menu in Colour mode.

In a B/W environment (IR is activated), the focus is adjusted as set in FOCUS IN BW

If "AF LIMIT<BW>" in FOCUS/ZOOM menu is ON, and over 20x Zoom ratio, FOCUS MODE changes to MANUAL.

If OFF, the focus is adjusted as set in FOCUS IN BW.

- **WDR**  
Lessens the contrast between dark and bright areas.

- **ATW**  
The White Balance setting for the current PRESET is selectable. It is set as follows:
  1. Select ATW menu.
  2. Press the IRIS OPEN KEY in SET.
  3. The method for setting ATW is the same as shown in section “2.3. ATW”.

**Caution**

When setting a PRESET and TILT is over 90°, PAN/TILT automatically moves to the position -20°~90° and TILT is limited to 90°.

### 3.2 TOUR

This function makes the camera repeatedly follow a series of pre-programmed presets.

<b>1. TOUR NO</b>	<b>1~5</b>
<b>2. TOUR NO DEF</b>	<b>OFF / ON</b>
<b>3. NAME</b>	<b>TOURGROUP1</b>
<b>4. TOUR NAME DEF</b>	<b>OFF / ON</b>
<b>5. DWELL TIME</b>	<b>1~120</b>
<b>6. EXIT</b>	

- **TOUR NO**  
A maximum of 5 groups can be registered.
- **TOUR NO DEF**  
OFF: TOUR Group setting is cancelled.  
ON: TOUR is set up.

Setting Example

TOUR NO	1	2	3	4	5
TOUR DEF	ON	OFF	ON	OFF	ON

TOUR will be executed in programmed preset 1, 3 & 5.

The method for setting TOUR GROUP 1 in PRESET is as follows:

1. Register "1" as a TOUR NO.
2. Change the status of TOUR NO DEF from OFF to ON and press the IRIS OPEN KEY.

<b>PRESET NUMBER</b>	<b>OFF / 1~128</b>
<b>PRESET NUMBER</b>	<b>OFF / 1~128</b>
<b>PRESET NUMBER</b>	<b>OFF / 1~128</b>
<b>PRESET NUMBER</b>	<b>OFF / 1~128</b>
<b>PRESET NUMBER</b>	<b>OFF / 1~128</b>
<b>EXIT</b>	

3. Input the desired PRESET number from 1 onward in sequential order.
4. Press the IRIS CLOSE KEY to finalise the setting.

- **NAME**

Change the name of a TOUR GROUP.

The method for changing the name is as follows:

1. First change TOUR NAME DEF from OFF to ON, then press the IRIS OPEN KEY.
2. Changing a Tour Group name uses the same method shown in "1.3 CAMERA NAME DISPLAY".

- **DWELL TIME**

Is the waiting time between a PRESET execution and moving to the next PRESET.

**Caution**

If TOUR GOURP1 PRESET is set up as follows.

<b>PRESET NUMBER</b>	<b>1</b>
<b>PRESET NUMBER</b>	<b>2</b>
<b>PRESET NUMBER</b>	<b>3</b>
<b>PRESET NUMBER</b>	<b>OFF</b>
<b>PRESET NUMBER</b>	<b>4</b>
<b>EXIT</b>	

After moving through PRESET1 > PRESET2 > PRESET3, the camera returns to PRESET1.

If any PRESET is "OFF" during an operation in serial order, the camera returns to the first preset.

### 3.3 SCAN

This function automatically moves the camera back and forth from one point to another.

1. SCAN NO	1 ~ 5
2. SCAN DEFINE	OFF / ON
3. NAME	SCANGROUP1
4. SCAN NAME DEF	OFF / ON
5. PANSTART POS	180
6. PAN END POS	350
7. TILT POS	45
8. SCAN SPEED	2°, 5°, 10°, 20° /SECOND
9. EXIT	

- **SCAN NO**

A maximum of 5 Scans can be registered.

- **SCAN NO DEF**

OFF: SCAN is cancelled

ON: SCAN can be set up (it should be ON for operation in AUTO RUN) Setting Example

SCAN NO	1	2	3	4	5
SCAN DEF	ON	OFF	ON	OFF	ON

SCAN will be executed in programmed preset 1, 3 & 5.

The method for setting up SCAN1 in PRESET is as follows:

1. Register "1" as the SCAN NO.
2. Change SCAN DEFINE from OFF to ON and press the IRIS OPEN KEY.

- **NAME**

This changes the SCAN Name.

The method for changing the SCAN NAME is as follows:

1. Change SCAN NAME DEF from OFF to ON and press the IRIS OPEN KEY.
2. The method for changing the SCAN name is the same as for "1.3 CAMERA NAME"

- **PAN START POS**

This sets up the initial location for the SCAN.

The method for setting up a SCAN is as follows:

1. Press the IRIS OPEN KEY in PAN START POS.

<b>PAN START POSITION</b>	<b>SET</b>
<b>PAN START POSITION</b>	<b>XXX</b>
<b>EXIT</b>	<b>IRIS CLOSE</b>

PAN Shift: LEFT, RIGHT KEY

2. After moving to the desired position, press the IRIS OPEN KEY.

- **PAN END POS**

This sets up the end position for the SCAN.

The method for setting up PAN END POS is the same as for PAN START POS.

- **TILT POS**

This sets up the TILT angle in the SCAN.

Set up is similar to “PAN START POS” but the UP, DOWN keys should be used.

- **SCAN SPEED**

Sets up the SCAN Speed.

The speed can be set between 2°/second (slow) ~ 20°/second (fast).

**Caution**

1. The values applied for WDR and ATW are those set on the OSD.
2. Set up angles of the initial and end location for the SCAN should not be over 180°.
3. Use AUTOPAN (A.PAN) for a continual PAN in SCAN.
4. If setting a SCAN with a TILT over 90°, PAN/TILT automatically moves to the position -20°~90° and TILT is limited to 90°

### 3.4 PATTERN

A PATTERN is a memorised

<b>1. PATT NUMBER</b>	<b>1~2</b>
<b>2. PATT DEFINE</b>	<b>OFF / ON</b>
<b>3. NAME</b>	<b>PATTERN001</b>
<b>4. PATTNAME DEF</b>	<b>OFF / &lt;ON&gt;</b>
<b>5. PATT RECORD</b>	<b>OFF / &lt;ON&gt;</b>
<b>6. PATT SPEED</b>	<b>2°,5,10,20°/S</b>
<b>7. EXIT</b>	

MENU Shift: UP, DOWN, LEFT & RIGHT KEYS

MENU Open: IRIS OPEN KEY

MENU Close: IRIS CLOSE KEY

- **PATT DEFINE**

OFF: PATTERN is cancelled

ON: PATTERN is set up.

If operating in AUTO RUN, PATT DEFINE should to be set to ON.

- **NAME**

Changes the PATTERN Name.

The method for setting up PATTERN NAME is as follows:

1. Change PATTERN NAME DEF from OFF to ON and press the IRIS OPEN KEY.
2. Changing the name uses the same method as shown in “1.3CAMERA NAME DISPLAY”.

- **PATT RECORD**

OFF: PATTERN is not memorised.

ON: PATTERN is memorised.

How to set up a PATTERN

1. Change PATT RECORD from OFF to ON and press the IRIS OPEN KEY.

<b>MEMORY FILL</b>	<b>XXX ( Recorded )</b>
<b>START</b>	<b>IRIS OPEN</b>
<b>EXIT</b>	<b>IRIS CLOSE</b>

PAN/TILT Shift: UP, DOWN, LEFT & RIGHT

2. Move PAN/TILT to the desired position before starting PATTERN.
3. Press the IRIS OPEN KEY to start the process
4. Press the IRIS CLOSE to save the process.

**Caution**

1. If there is no PAN/TILT movement, no PATTERN is memorised.
2. The values applied for WDR and ATW are those set on the OSD.
3. If a PATTERN is set with a TILT angle over 90°, PAN/TILT automatically moves to the position -20°~90° and TILT is limited to 90°

### 3.5 AUTO PAN

PAN is a 360° rotation according to the setting values - TILT ANGLE, DIRECTION and SPEED.

<b>1.TILT ANGLE:</b>	<b>&lt;XXX&gt;</b>
<b>2. PAN SPEED</b>	<b>2°,5°,10°,20°/S</b>
<b>3. DIRECTION</b>	<b>CW / CCW</b>
<b>4. EXIT</b>	

- **TILT ANGLE**

Move to TILT ANGLE and Press the MANU KEY. To finish, press the MANU KEY.

**Caution**

1. ZOOM is automatically switched to 1x.
2. WDR, ATW are set to FACTORY DEFAULT.
3. If set an AUTO PAN with TILT over 90°, PAN/TILT automatically moves to the position -20°~90° and TILT is limited to 90°.

#### 4. ZONE SET

1. AREA SEL	1 ~ 8
2. AREA DEFINE	OFF / ON
3. AREA COLOUR	BLACK / MOSAIC
4. AREA NEW SET	OFF / ON
5. HEIGHT EDIT	XXX
6. WIDTH EDIT	XXX
7. PAN ANGLE	XXX
8. TILT ANGLE	XXX
9. EXIT	

MENU Shift: UP, DOWN, LEFT & RIGHT KEYS

MENU Open: IRIS OPEN KEY

MENU Close: IRIS CLOSE KEY

For Privacy protection, use and set MOSAIC ZONE.

- **AREA SEL**

Up to 8 PRIVACY ZONES can be defined.

- **AREA DEFINE**

OFF: PRIVACY ZONE is not activated.

ON: PRIVACY ZONE is activated.

- **AREA COLOUR**

The colour of the MOSAIC ZONE is selectable.

- **AREA NEW SET**

OFF: Previous PRIVACY ZONE is activated.

ON: New PRIVACY ZONE is set up from the current PAN/TILT position

(when switching from OFF to ON the PRIVACY ZONE appears in the centre on the screen).



- **HEIGHT EDIT**  
Adjust the height of ZONE.
- **HEIGHT EDIT**  
Adjust the width of ZONE.
- **PAN ANGLE**  
Move a setting ZONE from side to side.
- **PAN ANGLE**  
Move a setting ZONE up and down.

### How to set up PRIVACY ZONE 1

1. When the MENU is OFF, locate the PRIVACY ZONE block in the centre of the screen using the PAN/TILT function.
2. Press the IRIS OPEN KEY to activate the MENU and move to “ZONE SET”. Then, press the IRIS OPEN KEY again.
3. Change AREA SEL to 1.
4. Change AREA DEFINE from OFF to ON.
5. Change AREA NEW SET from OFF to ON.
6. New ZONE is activated in the centre of the screen and the ZONE can be moved using the HEIGHT, WIDTH, PAN and TILT Menu.
7. Press the IRIS CLOSE KEY to finalise the set up.

### Caution

Please set a MASK within  $-20^{\circ}$ ~ $80^{\circ}$  of the TILT angle.

If a MASK is set at a TILT angle over  $90^{\circ}$ , PAN/TILT automatically moves to a position within  $90^{\circ}$ .

## 5. ALARM SET

1. ALARM DISPLAY	OFF/ON
2. ALARM IN	SET
3. ALARM OUT	OFF/ON
4. TIME OUT	1~10sec
5. EXIT	

- **ALARM DISPLAY**  
When signals are input from outside, the alarm number is displayed on the monitor.

- **ALARM IN**

Move to the PRESET by the detection of an ALARM INPUT from an external sensor.

#### How to set up PRESET

1. Move to ALARM IN, press IRIS OPEN KEY. The menu below is displayed.

1. IN1 PRESET NUM      OFF / 1~128  
2. EXIT

2. Set a PRESET number.
3. Move to EXIT and press the RIGHT KEY to finalise the set up.

- **TIME OUT**

Set a TIME OUT to determine the waiting time from PRESET to the reactivation of a TOUR after an ALARM IN has been received.

#### Caution

1. PRESET DEFINE must be set to ON to activate ALARM IN.
2. A ground signal from an external alarm must be maintained for a minimum of 200ms.

## 6. WIPER SET

AUTO: WIPER is activated at TILT angle within 80°~100°.

PUSH: WIPER is activated once.

RUN: WIPER ON

STOP: WIPER OFF

Select the menu using the Joystick and press the IRIS OPEN to activate.

## 7. INITIALISE SET

1. POWER ON RESET

2. PAN/TILT INIT

3. CAMERA INIT

4. AUTO SEQ INIT

5. PRIVACY ZONE INIT

6. FACTORY INIT

7. EXIT

MENU Shift: UP, DOWN  
MENU Open: IRIS OPEN KEY  
MENU Close: IRIS CLOSE KEY

- **POWER ON RESET**

The unit is initialised.

- **PAN/TILT INIT**

1. PAN/TILT MENU is initialised.
2. PAN/TILT location is initialised.

- **CAMERA INIT**

Only the CAMERA setting menu is initialised.

- **AUTO SEQ INIT**

1. Only the AUTO SEQ menu is initialised.
2. PRESET information and PATTERN memory are not initialised.

- **PRIVACY ZONE INIT**

PRIVACY ZONE is initialised.

- **FACTORY INIT**

All Menu set ups are reset to factory defaults.

### WTX-1200A – Simple PRESET Setting

The following keyboard controller can be used for camera commands when the OSD MENU is not activated.

#### How to set up a PRESET



Presetnumber



PRESET (F1)

1. Move the camera to the desired PAN/TILT/ZOOM location using the Joystick.
2. Press No. 1 on the keyboard
3. Press and hold the F1 Key until “SETTED” appears in the bottom right on the screen.

**Caution**

When using the shortcut key to set PRESETS, they can be in the range 1-64. With regard to PRESETS of 65 and over, these should be set up using the OSD Menu.

**WTX-1200A – Simple PRESET Shift**



Press the PRESET number followed by the F1 key and the camera moves to the corresponding PRESET position. However, this is only valid up to PRESET no. 32 for which PRESET DEFINE is set to ON.

**WTX-1200A - Simple TOUR Operation**

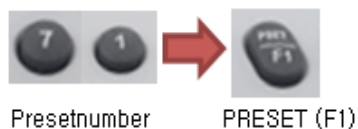

Press number 71 on the keypad followed by the F1 key. This works when TOUR DEFINE is ON and the TOUR related MENU is properly set up.

**WTX-1200A- Simple PATTERN Operation**



Press number 66 on the keypad followed by the F1 key. This works when PATTERN DEFINE is ON and the PATTERN related MENU is properly set up.

**WTX-1200A - Simple SCAN Operation**



Press number 81 on the keypad followed by the F1 key. This works when SCAN DEFINE is ON and the SCAN related MENU is properly set up.

### WTX-1200A - Simple Sequence Operation



Press the F1 key shortly after pressing keypad 70. This works when PRESET is set up.

### Quick Operation Key Table

#### [PELCO D /P PROTOCOLS]

Number	Function
1~64+Preset	Setting Preset Press Preset button for more than 2 seconds
1~64+Preset	Executing Preset
65+Preset	Executing A.PAN
66+Preset	Executing Scan
70+Preset	Executing Sequency
71+Preset	Executing Tour
81+Preset	Executing Pattern
84+Preset	Wiper Run
86+Preset	Wiper (1 time operation)
80+Preset	Wiper Stop
95+Preset	IRIS OPEN (OSD Menu)
96+Preset	IRIS CLOSE
67+Preset	Executing AUTO Focus
68+Preset	Executing MANU

- **How to operate MAIN MENU**  
95+GO PRESET(MENU KEY)
- **How to operate SUB MENU**  
95+ GO PRESET(MENU KEY) or Press IRIS OPEN
- **How to operate MAIN EXIT**
  1. Move to "EXIT" and Press MENU KEY or IRIS OPEN .
  2. Press IRIS CLOSE or 96+GO PRESET

## Specification

<b>Video</b>	
CCD Sensor	1/4" Sony Super HAD CCD
Total Pixels	PAL: 610K
H. Resolution	700TV Lines (750TV Lines in B/W)
Auto Iris Type	DC IRIS
Lens	3.4~122.4mm 36x Optical Zoom
Focus System	Automatic
S/N Ratio	More than 50dB (AGC Off)
M.Illumination	0Lux (with IR LED's On)
IR Distance	100 Metres in Ideal Conditions
Pan/Tilt	PAN 360°, Tilt -25°~205°
<b>OSD/DSP</b>	
Digital Zoom	OFF / 1x~32x
Day & Night	COLOUR / BW / AUTO (ICR)
BLC	ON / OFF
WDR	ON / OFF
Shutter Speed	AUTO / MANUAL (1/50~1/100000 sec)
White Balance	AUTO / ATW / INDOOR / OUTDOOR / ONEPUSH / MANUAL
Video Gain Control	0~15 Level
Noise Reduction	2D/3D (OFF/MANUAL / AUTO )
Privacy Zone	ON/OFF (8 Programmable Zones)
Presets	128 Programmable
Digital Flip	ON / OFF
Focus Control	AUTO / ZOOMMTG / MANUAL
Wipe	AUTO / PUSH / RUN
IR Angle	AUTO / 6°~60°
Motion Detection	ON / OFF
DIS	Yes
<b>Connectors/Switches/Mechanical</b>	
Video Out	BNCx1,1.0Vpp, 75Ω, Composite
Alarm Input	1
Alarm Ouput	1
RS485	Pelco D/P & other protocols
<b>Other</b>	
Environment	IP68
Power	AC24V 60W@Heater/Blower
Operating Temp.	-40°F~122°F
Dimension	200 x 469mm (Diameter x Height)
Weight	13.5Kg

Dimensions (mm)

