

# SW1

---

## 2-Way Push-Pull Subwoofer

## Owner's Manual

# TABLE OF CONTENTS

|  |    |
|--|----|
| Introduction                                 | 2  |
| General Information                          | 3  |
| Check Speaker and Parts                      | 3  |
| General Care of Your Subwoofer and Amplifier | 3  |
| Bass and Loudness Contour Controls           | 3  |
| SW1 Location; Multiple Subs Location         | 3  |
| Amplifier Location                           | 4  |
| Speaker Wire                                 | 4  |
| Speaker Information                          | 5  |
| Subwoofer Design                             | 5  |
| SW1 Push-Pull Design                         | 5  |
| Installing the SW1 With A2 Amplifier         | 6  |
| Installing the SW1 With A3 Amplifier         | 8  |
| SW1 Specifications                           | 10 |
| A2 Subwoofer Specifications                  | 11 |
| A3 Subwoofer Specifications                  | 12 |
| Warranty                                     | 13 |
| Contacts                                     | 14 |

# INTRODUCTION

Congratulations on your selection of the Induction Dynamics™ SW1 Twin 15" Push-Pull closed-box subwoofer. Designed for both two-channel audio and digital surround sound, the SW1 features an innovative subwoofer configuration where dual subwoofers in each cabinet are mounted in a compound push-pull configuration. Mounting the drivers in this way allows them to act as a single driver with double the mass and double the motor strength, yet requiring an enclosure only half the size needed by a single driver. The compound push-pull configuration reduces subwoofer distortion and improves bass control.

The SW1 is a powered subwoofer, with two amplification options:

Choosing the external A2 subwoofer amplifier allows greater placement flexibility; since the amp will be mounted with other equipment, the subwoofer itself can be placed freestanding or built into walls, ceilings or floors.

The A3 internal subwoofer amplifier is advantageous in that it saves space in the equipment area. Like all amplifiers, the A3 will create heat, so an SW1 with A3 amplifier should NOT be built into walls, etc.

Built to the highest standards of perfection, the SW1 makes an excellent addition to any home theater, but to achieve the highest quality sound, we recommend using it in conjunction with Induction Dynamics speakers. For a full catalog, contact Induction Dynamics at sales@inductiondynamics.com or by calling toll free (866) 663-9770.

## **WARNINGS:**

**WARNING! - SHOCK HAZARD**

**WARNING! - DO NOT OPEN  
NO USER-SERVICEABLE PARTS INSIDE  
REFER SERVICING TO QUALIFIED PERSONNEL**

# GENERAL INFORMATION

Please read these instructions thoroughly before attempting to install and operate the SW1 subwoofer.

## ***Check Speaker and Parts***

Unpack and carefully check each loudspeaker. If you suspect damage from transit, report the problem immediately to your dealer and/or delivery service.

If possible, save the shipping cartons for future use. Please ship the foam packing material to: Induction Dynamics, 10661 René, Lenexa KS 66215.

## ***General Care of Your Loudspeaker and Amplifier***

Whenever changing speaker wires, interconnect wires, or power cords, always turn off all equipment. To prevent fire or shock hazard, do not expose the amplifier to rain or excessive moisture. To avoid electric shock, do not open the amplifier. There are no user-serviceable parts inside.

Your subwoofer and amplifier come in a high quality finish that is both attractive and durable. To clean, use a soft, damp cloth. If your drivers become dusty, dust them with a paintbrush or a brush vacuum attachment. Do not use a strong or abrasive cleaner.

The grille is covered in acoustic cloth. To keep your grille clear of debris, we recommend you use a lint roller (like you would use on clothes).

## ***Bass and Loudness Contour Controls***

Do not use bass or loudness contour controls. Induction Dynamics' subwoofers produce very low frequencies without these controls. Use of these controls will make the bass sound "boomy", obscure higher frequencies, and possibly cause damage due to excessive cone excursion.

## ***SW1 Location***

The SW1 is normally freestanding within the listening environment, but may be built into walls if used with the A2 external subwoofer amplifier.

Where possible, it is generally best to use two subwoofers, each located in a different area of the room. In addition to improving efficiency and doubling the power handling, using two subwoofers creates a more even distribution of the low frequencies by reducing peaks and nulls. Two SW1s must be connected in series.

## ***Amplifier Location***

The A2 amplifier is best located in an equipment rack or shelving with other audio and video equipment. It is not recommended for placement behind walls or other limited access locations, where service may be restricted.

The A3 amplifier is built in to the SW1. If you chose the A3 option, make sure to place your SW1 in an open area with plenty of ventilation. Do NOT build in to walls or place the SW1 in a closed area.

## ***Speaker Wire***

Use approved wire designed for in-wall or exposed use, as appropriate for your installation. For the SW1, we recommend using high-quality speaker wire that is 12 gauge or lower, with easily visible polarity coding to make your connections. The following chart identifies minimum gauge requirements for various lengths. See your local dealer or installation contractor for more information.

| <b>WIRE LENGTHS / MINIMUM GAUGE REQUIREMENTS</b> |                                 |
|--|---------------------------------|
| <b>Length (in feet)</b>                          | <b>AWG size &amp; stranding</b> |
| <b>up to 18'</b>                                 | <b>14 gauge (18/27)</b>         |
| <b>up to 29'</b>                                 | <b>12 gauge (65/30)</b>         |
| <b>up to 61'</b>                                 | <b>10 gauge (105/30)</b>        |

# SUBWOOFER INFORMATION

## ***Subwoofer Design***

Non-realistic, “boomy” bass frequencies are so prevalent in the home theater world that some listeners have never heard a well-tuned subwoofer. The “boom” occurs because every subwoofer has a natural resonance peak—that is, every subwoofer will naturally produce a narrow range of low frequencies at a higher volume than the rest. This “boom” drowns out higher frequencies your subwoofer produces, resulting in diminished performance and muddy, poor-quality bass.

Induction Dynamics® engineers its subwoofers with high-performance drivers and specialized filter circuits to eliminate resonance peaks and produce a fuller sound expressing all bass frequencies.

Most subwoofers do not attempt to reproduce ultra-low frequencies because of the distortion created by excess excursion. Induction Dynamics eliminates this distortion with a patented frequency-selective excursion limiter. The excursion limiter allows the subwoofer to produce ultra-low frequency sound but prevents the driver from overexerting and causing distortion that could ruin your listening experience; the limiter itself is transparent, operating only at specific frequencies without audibly switching on and off.

## ***SW1 Push-Pull Design***

The SW1 features an innovative subwoofer configuration where dual subwoofers in each cabinet are mounted in a compound push-pull configuration. Mounting the drivers in this way allows them to act as a single driver with double the mass and double the motor strength, yet requiring an enclosure only half the size needed by a single driver. The compound push-pull configuration reduces subwoofer distortion and improves bass control.

# INSTALLING THE SW1 WITH A2 AMPLIFIER

The A2 is designed to be used with audio/video pre-amplifiers and receivers that have their own built-in low frequency crossover circuits. These circuits typically have a low pass rolloff of 12dB/octave or 24 dB/octave. The best crossover frequency setting is usually 60 Hz (12 dB/octave low pass) or 70 Hz (24 db/octave low pass). Ultimately, the crossover frequency setting is best determined by consulting your own ears.

## ***Connecting the A2 to Your SW1***

1. Turn off the power to each piece of equipment before making any connections.
2. Using high-quality interconnect cables with RCA type terminations, connect the "SUBWOOFER OUT" on the audio/video preamplifier or receiver to "IN" on the A2. If using a single subwoofer, proceed to step 3; if using two subwoofers, skip step 3 and proceed to step 4.
3. Using high-quality speaker wire (consult the chart on page 4), connect the black binding post on the A2 to the black binding post on the SW1 subwoofer and connect the red binding post on the A2 to the red binding post on the SW1 subwoofer. Proceed to step 5.
4. If using a single A2 with two subwoofers, the subs must be connected in series. In this configuration, the two 4-ohm loads will combine to create an 8-ohm load. Connect the red binding post of the A2 amplifier to the red binding post on the first subwoofer, and the black binding post on the A2 amplifier to the black binding post on the second subwoofer. Then connect the black binding post on first subwoofer to the red binding post on the second subwoofer. Three subwoofer connection methods are shown on the opposite page. Proceed to step 5.
5. Connect the amplifier to a 120-volt, single phase, 60-Hz, grounded power supply using the power cord provided. For best results, use a dedicated power circuit for your amplification equipment.
6. Phase Check: Listen to the subwoofer(s) and higher frequency speakers together. Then, reverse the speaker wires on the back of the subwoofer (black to red and red to black). This reverse connection is 180° out of phase with the normal connection. One of these two arrangements will sound noticeably louder in the low-frequency range. The louder arrangement is the proper phase alignment for your installation.

7. Volume Adjustment: The subwoofer volume level may be adjusted by using the control in the menu of the audio/video preamplifier or receiver. The subwoofer volume level may be measured using a sound level meter, a real time analyzer, or adjusted by ear. An easy technique is to set the level just below where it starts to sound “boomy”.

Method 1:

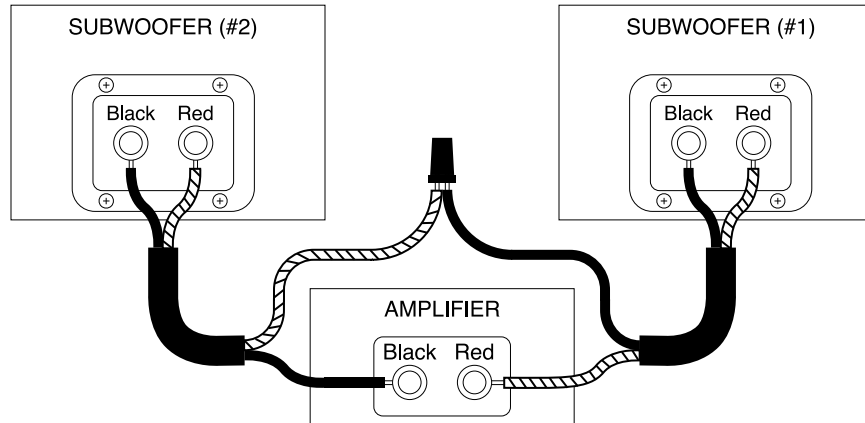

Method 2:

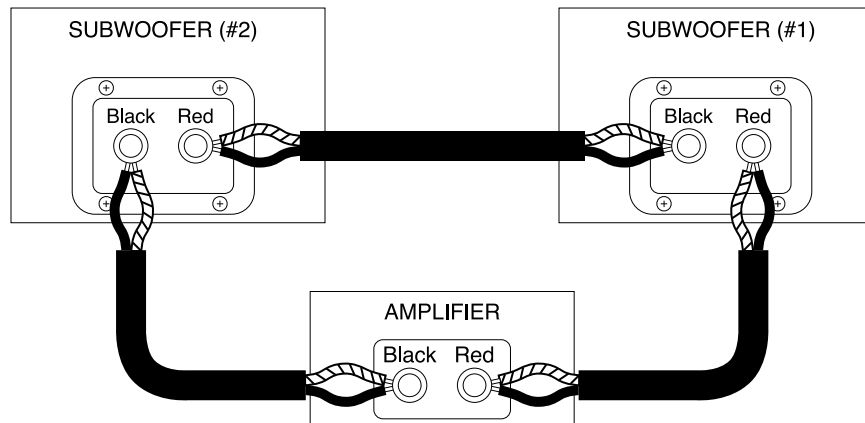

Method 3:

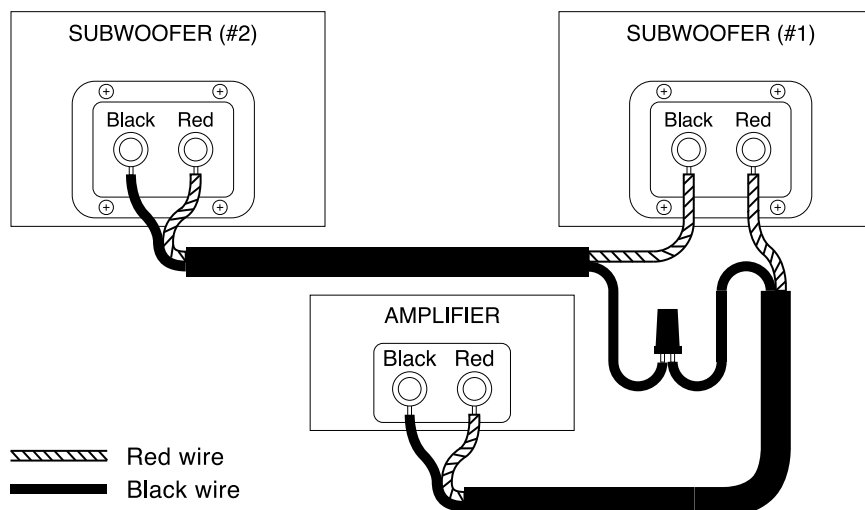



# INSTALLING THE SW1 WITH A3 AMPLIFIER

The A3 amplifier has a built-in adjustable low-pass crossover with a bypass switch on the back panel. This allows the subwoofer to be used with audio/video pre-amplifiers and receivers that have their own built-in low-frequency crossover circuits.

## ***Connecting the A3 to Your Amplifier/Receiver***

The SW1 has several connection options. Read through steps 1 - 4 and choose the applicable method for your setup, then proceed to step 5.

### 1. Standard Subwoofer Connection - preamp or receiver with sub output

Using high-quality interconnect cables with RCA type terminations, connect the SUBWOOFER OUT on the audio/video preamplifier or receiver to either the L or R LOW LEVEL inputs on the back of the A3 amplifier. In this configuration you will use the built-in crossover circuits in the audio/video preamplifier or receiver so the low-pass switch on the A3 amp should be in the “out” position. This bypasses the crossover. Proceed to step 5.

### 2. Connecting Multiple Subwoofers - preamp or receiver with sub output

Using high-quality interconnect cables with RCA type terminations, connect the SUBWOOFER OUT on the audio/video preamplifier or receiver through a Y-connector to either the L or R LOW LEVEL inputs on the backs of both A3 amplifiers. In this configuration you will use the built-in crossover circuits in the audio/video preamplifier or receiver so the low-pass switch on the A3 amp should be in the “out” position. This bypasses the crossover. Proceed to step 5.

### 3. Special Low-Level Stereo Connection - preamp or receiver without sub output

Using high-quality interconnect cables with RCA type terminations, connect the RIGHT and LEFT PREAMP OUT on the audio/video preamplifier or receiver through two Y-connectors to the corresponding L IN or R IN on the A3. Then, connect the free leg of the Y-connectors to the L and R inputs on the audio/video receiver or amplifier used to power the higher frequency range speakers. In this configuration you will use the low-pass crossover in the A3 amplifier, so the low-pass switch on the A3 amp should be in the “in” position. Proceed to step 5.

#### 4. Special High-Level Stereo Connection - preamp or receiver without sub output

The high-level method is recommended for setups where the receiver is a long distance from the main left and right speakers and subwoofer.

Connect the L and R speaker leads from the main amp directly to the high-level terminals marked FROM AMPLIFIER on the A3 amp. Then connect a second pair of speaker leads to your L and R main speakers. The high-level terminals are capable of connecting leads terminated with either bare wire ends or “banana” plugs. If your leads have “banana” plugs on them, the plastic decorative plugs may be removed from the high-level terminals on the A3 amplifier. When using the high-level terminals, be sure to verify the positive leads are connected to the red terminals and the negative leads are connected to the black terminals on all connections. In this configuration you will use the low-pass crossover in the A3 amplifier, so the low-pass switch on the A3 amp should be in the “in” position. Proceed to step 5.

5. Connect the amplifier to a 120-volt, single phase, 60-Hz, grounded power supply using the power cord provided. For best results, use a dedicated power circuit for your amplification equipment.

6. If you used connection method 3 or 4, you will need to adjust the low pass. Initially, set the low pass at the lowest frequency specified by the manufacturer for the main speakers. For example, if the frequency response of your mains is specified as 55-20,000 Hz, set the low pass at 55 Hz. Later, after setting volume level and checking phase, you can fine tune the low pass setting.

7. Due to varying processor designs and possible phase switches, it is best to check the phase of your SW1 for proper alignment. Your SW1 with built-in A3 amplifier has a phase switch on the back panel. To test for proper phase, play some music that has some low-frequency sound. Listen to the subwoofer and higher frequency speakers together. With an assistant manning the phase switch, listen to the frequencies slightly above the lowest frequencies (at crossover), asking the assistant to switch between the two positions. One of these two positions will sound noticeably louder in the crossover frequency range. The louder position is the proper phase alignment for your installation.

8. You can adjust the subwoofer level using the gain control on the back of the A3 amplifier. The gain control is precisely stepped in 1/2 dB increments, allowing settings for various applications to be easily repeated. For flexibility, a 3-position switch is provided which allows the selection of additional gains of +10, 0, -10 dB; these gain controls are in addition to the control in the menu of the audio/video preamplifier or receiver.

# SW1 SPECIFICATIONS

---

|                                   |  |
|-----------------------------------|--|
| <b>Type:</b>                      | Powered subwoofer  |
| <b>Driver Control:</b>            | High-saturation filter circuit to eliminate resonance peaks                                  |
| <b>Nominal Impedance:</b>         | 4 Ohms (2.5 minimum)   |
| <b>Frequency Response:</b>        | 24 - 150 Hz  |
| <b>Sensitivity (2.83 V @ 1M):</b> | 86 dB  |
| <b>SPL (1 W / 1 m):</b>           | 83 dB  |
| <b>Power Handling:</b>            | 500 W  |
| <b>Magnetic Shielding:</b>        | No   |
| <b>Drivers:</b>                   | (2) 15" laminated cones in push-pull configuration with rubber surrounds and 120-oz. magnets |
| <b>Binding Posts:</b>             | Gold-plated; #4 AWG Max  |
| <b>Enclosure:</b>                 | Sealed   |
| <b>Optional Accessories:</b>      | ST2.SW1 dual-post subwoofer stand  |

---

# A2 SPECIFICATIONS

|   |  |
|---|--|
| <b>Type:</b>  | Class AB Bipolar Subwoofer Amplifier                                   |
| <b>Driver Control:</b>  | Patented non-distorting, frequency-selective excursion limiter         |
| <b>Frequency Response:</b>  | 20 Hz - 20 kHz, +/- 0.25 dB  |
| <b>Harmonic Distortion:</b>   | < 0.078% (@ 1 kHz, 1 Watt)   |
| <b>Voltage Gain (dB) S/N:</b>   | 36 dB (internally switchable to 26 dB)                                 |
| <b>Damping Factor:</b>  | 95 dBA   |
| <b>Input Impedance:</b>   | 400 Ohms @ 60 Hz   |
| <b>Output Load:</b>   | 2.5 K Ohms minimum   |
| <b>Power Output<br/>(Continuous)<br/>2.5 Ohms / 4 Ohms /<br/>8 Ohms</b> | 700 Watts / 520 Watts / 300 Watts                                      |
| <b>Inputs:</b>  | 1 RCA (RCA plus XLR optional)  |
| <b>Output Binding Posts:</b>  | Gold Plated; #10 AWG max, or Banana Plugs                              |
| <b>Power Requirements:</b>  | 120 V AC, 6A slow-burn fuse  |
| <b>Auto On/Off</b>  | Auto power down if no signal for 20 minutes (turn-on sensitivity 2 mV) |

# A3 SPECIFICATIONS

---

|   |   |
|---|---|
| <b>Type:</b>  | Class AB Bipolar Subwoofer Amplifier with 2-stage power supply                                    |
| <b>Driver Control:</b>  | Patented non-distorting, frequency-selective excursion limiter                                    |
| <b>Frequency Response:</b>  | 20 Hz - 20 kHz, +/- 0.25 dB   |
| <b>Harmonic Distortion:</b>   | < 0.05% (@ 1 kHz, 1 Watt)   |
| <b>Voltage Gain (dB) S/N:</b>   | 38 dB (internally switchable to 28 dB or 48 dB plus rotary gain control +/- 9 dB in 1/2 dB steps) |
| <b>Damping Factor:</b>  | 95 dBA  |
| <b>Input Impedance:</b>   | 300 Ohms @ 60 Hz  |
| <b>Output Load:</b>   | 2.5 K Ohms minimum  |
| <b>Power Output<br/>(Continuous)<br/>2.5 Ohms / 4 Ohms /<br/>8 Ohms</b> | 640 Watts / 500 Watts / 360 Watts   |
| <b>Inputs:</b>  | L & R RCA Low and high levels (RCA plus XLR optional without high levels)                         |
| <b>Output Binding Posts:</b>  | N/A   |
| <b>Power Requirements:</b>  | 120/240 V AC; 50/60 Hz; 6A slow-burn fuse   |
| <b>Level Controls:</b>  | 120/240 V AC; 50/60 Hz; 6A slow-burn fuse   |
| <b>Auto On/Off</b>  | Auto power down if no signal for 20 minutes (turn-on sensitivity 2 mV)                            |

---

# WARRANTY

Induction Dynamics, Inc. warrants the SW1 subwoofer, A2 amplifier, and/or A3 amplifier against defects in materials and workmanship for a period of seven years from the date of original retail purchase. Induction Dynamics, Inc. will repair or replace any SW1 subwoofer, A2 amplifier, and/or A3 amplifier that does not meet this warranty.

This warranty may be registered by mailing a copy of the retail sales receipt to Induction Dynamics, Inc. at the address below. Please write the serial number along with the name and address of the retailer from whom you purchased the speaker(s) and/or amplifier(s). This may be done at the time of purchase or before requesting repair service under this warranty.

To obtain repair service, call or write to Induction Dynamics, Inc. at the phone number or address below. You will be given a return authorization number. Please mark this number clearly on the outside of the package(s) for identification. Packages that are not marked with a return authorization number on the outside may not be accepted by Induction Dynamics, Inc. Please pack each SW1 subwoofer, A2 amplifier, and/or A3 amplifier in a substantial shipping container with plenty of protective foam. If possible, use the original shipping container and packing material. For repairs covered by and performed under this warranty, Induction Dynamics, Inc. will pay for the return shipping charges. This warranty covers defects in materials and workmanship, and does not cover damage or failure resulting from accident, misuse, or shipment. The warranty is void if the SW1 subwoofer, A2 amplifier, and/or A3 amplifier is serviced or altered by anyone other than Induction Dynamics, Inc. the sole remedy for breach of this warranty shall be repair or replacement.

**Limits and Exclusions: There are no warranties except as mentioned above. Neither Induction Dynamics, Inc. nor anyone else who has been involved in the creation, production, or sale of this product shall be liable for any direct, indirect, consequential or accidental damages arising out of the use or inability to use this product, or arising out of breach of this warranty. Induction Dynamics, Inc. makes no other warranties, express or implied, including without limitation warranties of merchantability or fitness for a particular purpose. There are no warranties that extend beyond the description on the face hereof.**

Induction Dynamics  
Customer Service Department  
8005 W. 110th St., Suite 208  
Overland Park, KS 66210  
USA

Phone: 855.663.5600  
Fax: 913.663.3200

# CONTACTS

## ***Manufacturer Information***

If you have any questions, contact Induction Dynamics by phone at 855-663-5600, 8:00 a.m.- 5:00 p.m. CST, fax at 913-663-3200, email at [sales@inductiondynamics.com](mailto:sales@inductiondynamics.com), or write to:

Induction Dynamics  
Customer Service Department  
8005 W. 110th St., Suite 208  
Overland Park, KS 66210  
USA

Note: Please do not ship your loudspeaker for service without obtaining prior approval and return authorization number. See warranty for further information.

## ***Retailer Information***

To help simplify your record keeping, please fill out the following information about the retailer you bought your Induction Dynamics products from. Additionally, you may staple, tape, or glue a copy of your receipt to the next page.

Retailer name (company or individual): \_\_\_\_\_

Address: \_\_\_\_\_

City: \_\_\_\_\_

State: \_\_\_\_\_

Zip or Postal code: \_\_\_\_\_

Phone: \_\_\_\_\_

Email: \_\_\_\_\_

Date of purchase: \_\_\_\_\_

Serial number: \_\_\_\_\_

To simplify your record keeping,  
please glue, staple, or tape your receipt  
to this page.





# *Audio Perfection Realized*



**INDUCTION DYNAMICS®**

8005 W. 110th Street, Suite 208  
Overland Park, KS 66210  
Tel: (855) 663-5600  
Fax: (913) 663-3200  
[www.inductiondynamics.com](http://www.inductiondynamics.com)

© Induction Dynamics®, August 2013