

ID1

4-Way/3-Way Loudspeaker with Dual Subwoofers

Owner's Manual

TABLE OF CONTENTS

Introduction	2
General Information	3
Check Speaker and Parts	3
General Care of Your Loudspeaker and Amplifier	3
Bass and Loudness Contour Controls	3
ID1 Location	3
Amplifier Location	4
Carpet Spikes	4
Speaker Wire	4
Speaker Information	5
S4X Crossover	5
Wide Angle Phase Alignment	6
Subwoofer Design	7
Dual Loudspeaker Switch	7
Two-Channel (Stereo) Installation	8
Speaker Placement	8
Connecting Speakers in Stereo Mode	8
Multi-Channel (Home Theater) Installation	9
Speaker Placement	9
ID1 Main Speaker Connection	10
Subwoofer Amplifier Interconnect	10
Subwoofer Connection	10
Power Connection	10
ID1 Specifications	12
A2 Subwoofer Specifications	13
Warranty	14
Contacts	15

INTRODUCTION

Congratulations on your selection of the Induction Dynamics ID1 dual purpose loudspeaker. In order to provide greater flexibility and cater to listeners' preferences, the ID1 includes a unique switch on the back side of the speaker cabinet. This toggle switches the lower crossover in and out, allowing users to operate their speakers as either a 3-way plus subwoofer (home theater) or as a 4-way (stereo).

The ID1 incorporates exclusive, patented S4X™ crossover and driver-control technology, which makes possible virtually perfect integration of drivers which are ideal for their intended frequencies. S4X also provides greatly increased control over frequency response, phase, and impedance, resulting in superior performance and imaging. Because of S4X technology, any of Induction Dynamics' speakers can be used to build a custom home theater system. Your ID1 can be combined with any of our center channel and surround speakers, be they in-wall, on-wall, or free-standing.

Your ID1 incorporates dual 10" mica-graphite poly cone subwoofers. Induction Dynamics subwoofers accurately produce bass frequencies clearly and without distortion due to patented circuitry within the speaker cabinet. The specified deep bass capability is measured using closed-miked and outdoor ground-plane techniques that are free from measurement distortion caused by room reflections.

The ID1 is available in Rosewood Gloss, Black Satin, and Black Gloss standard finishes. Custom paints and stains are also available. Grille fabric is available in 63 room-complementing colors.

WARNINGS:

WARNING! - SHOCK HAZARD

**WARNING! - DO NOT OPEN
NO USER SERVICEABLE PARTS INSIDE
REFER SERVICING TO QUALIFIED PERSONNEL**

GENERAL INFORMATION

Please read these instructions thoroughly before attempting to install and operate the ID1 or A2 amplifier.

Check Speaker and Parts

Unpack and carefully check each loudspeaker. If you suspect damage from transit, report the problem immediately to your dealer and/or delivery service.

If possible, save the shipping cartons for future use. Please ship the foam packing material to: Induction Dynamics, 10661 Rene, Lenexa KS 66215.

General Care of Your Loudspeaker and Amplifier

Whenever changing speaker wires, interconnect wires, or power cords, always turn off all equipment. To prevent fire or shock hazard, do not expose the amplifier to rain or excessive moisture. To avoid electric shock, do not open the amplifier. There are no user serviceable parts inside.

Your speakers and amplifier come in a high quality finish that is both attractive and durable. To clean, use a soft, damp cloth. If your drivers become dusty, dust them with a paintbrush or a brush vacuum attachment. Do not use a strong or abrasive cleaner.

The grille is covered in acoustic cloth. To keep your grille clear of debris, we recommend you use a lint roller (like you would use on clothes).

Bass and Loudness Contour Controls

Do not use bass or loudness contour controls. Induction Dynamics' subwoofers produce very low frequencies without these controls. Use of these controls will make the bass sound "boomy", obscure higher frequencies, and possibly cause damage due to excessive cone excursion.

ID1 Location

The ID1 is normally freestanding within the listening environment, but may be built into walls.

Freestanding loudspeakers allow for maximum flexibility in changing their position within the listening environment. After the loudspeaker is connected, experiment with the placement in the listening room.

Amplifier Location

The A2 amplifier is best located in an equipment rack or shelving with other audio and video equipment. It is not recommended for placement behind walls or other limited access locations, where service may be restricted.

Carpet Spikes

Carpet spikes are not required with the ID1. However, they have been provided if you would prefer to use them. Should you choose to do so, lay the ID1 on its back side, then screw the carpet spikes into the threaded holes under the base of each speaker.

Speaker Wire

Use approved wire designed for in-wall or exposed use, as appropriate for your installation. For the ID1, we recommend using high-quality speaker wire that is 12 gauge or lower, with easily visible polarity coding to make your connections. The following chart identifies minimum gauge requirements for various lengths. See your local dealer or installation contractor for more information.

WIRE LENGTHS / MINIMUM GAUGE REQUIREMENTS	
Length (in feet)	AWG size & stranding
up to 18'	14 gauge (19/27)
up to 29'	12 gauge (65/30)
up to 51'	10 gauge (105/30)

SPEAKER INFORMATION

S4X™ Crossover

The heart of Induction Dynamics® is found in the S4X™ Super Fourth-Order Crossover. The patented S4X inductively couples crossover coils and optimizes each driver's performance, individually and interactively with the other drivers. This greatly increases control over driver range, frequency response, phase and impedance. Because S4X produces such a steep crossover slope—and thus a flatter frequency response—Induction Dynamics is able to use the best possible drivers for each range of frequencies, allowing us to sonically match every speaker in our lineup and to create speaker models able to perform in any combination and in any acoustic environment.

The S4X' optimized frequency response means music that moves dramatically up and down in pitch will never fade in or out, but rather maintain its power as it seamlessly crosses over from one driver to the next. It also means that frequencies critical to human speech (frequencies that deliver consonants like "S" and "C") will sound as natural coming from your speakers as they would in real life—making dialogue from movies and television sound crisp and clearly understood.

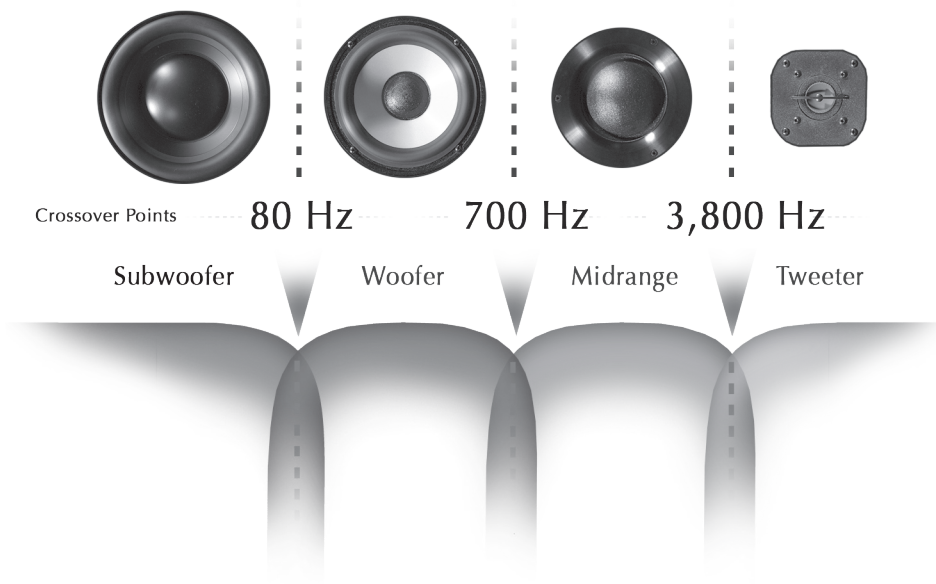

Above: The S4X crossover routes audio signal to their intended drivers at specific frequencies (80 Hz, 700 Hz, 3,800 Hz). Because the S4X produces such a steep crossover slope, Induction Dynamics is able to use the best possible drivers for each frequency range.

Wide Angle™ Phase Alignment

In each crossover region, which spans approximately one octave, the sound from two different drivers must be added together. This simple fact creates problems in most speakers, because the phase must be matched, not just on axis, but also off axis in order to create a large “sweet spot” for the listener. Most speakers’ drivers are only optimized on-axis, using measurements from a microphone placed at a single point in front of the speaker. This produces a horizontal zone in which the sound is optimized; however there may be drastic differences in sound quality along the vertical axis—meaning there may be a loss of sound quality if you stand up, sit, or otherwise move out of the optimized zone.

Induction Dynamics® eliminates phase differences with respect to height through our Wide Angle™ phase alignment technology. Because our patented circuitry provides additional variables that can help control phase, Wide Angle finds the one optimization solution that produces a flat frequency response along the vertical axis, when the microphone (or listener’s ear) is moved up and down vertically. This means you experience true audio perfection whether you’re standing, sitting, or lying down.

CONVENTIONAL SPEAKER SYSTEM

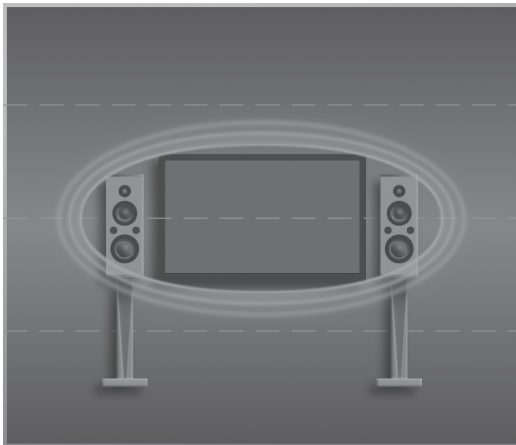

Most conventional speaker designs have a small and horizontally narrow “sweet spot” caused by inaccurate phase matching of the drivers. The best quality sound can be heard only within a very confined area. Outside of this area the sound quality can drastically decrease, becoming muddy or indistinct.

WIDE ANGLE™ PHASE ALIGNMENT

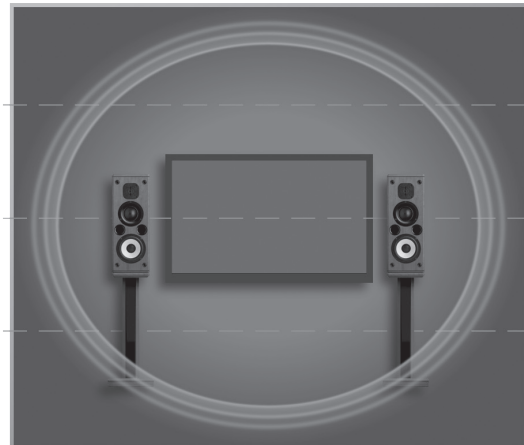

Approximate
ear level
while standing

Approximate
ear level
while seated

Approximate
ear level
while reclining

Patented Wide Angle™ Phase Alignment circuitry provides precise phase matching of the drivers, noticeably expanding the “sweet spot” both horizontally and vertically. Listeners are immersed in a large sound field and enjoy clear, undistorted sound regardless of their position relative to the speakers.

Subwoofer Design

Non-realistic, “boomy” bass frequencies are so prevalent in the home theater world that some listeners have never heard a well-tuned subwoofer. The “boom” occurs because every subwoofer has a natural resonance peak—that is, every subwoofer will naturally produce a narrow range of low frequencies at a higher volume than the rest. This “boom” drowns out higher frequencies your subwoofer produces, resulting in diminished performance and muddy, poor-quality bass.

Induction Dynamics® engineers its subwoofers with high-performance drivers and specialized filter circuits to eliminate resonance peaks and produce a fuller sound expressing all bass frequencies.

Most subwoofers do not attempt to reproduce ultra-low frequencies because of the distortion created by excess excursion. Induction Dynamics eliminates this distortion with a patented frequency-selective excursion limiter. The excursion limiter allows the subwoofer to produce ultra-low frequency sound but prevents the driver from overexerting and causing distortion that could ruin your listening experience; the limiter itself is transparent, operating only at specific frequencies without audibly switching on and off.

Dual Loudspeaker Switch

In order to provide greater flexibility and cater to listeners’ preferences, Induction Dynamics® includes a unique switch on the ID1. This toggle switches the lower crossover in and out, allowing users to operate their speakers as either a 3-way plus subwoofer (home theater) or as a 4-way (stereo).

To listen to these speakers in stereo mode, powered by a single stereo amplifier, place the switch in the 4-way position. In this mode, a passive crossover between the subwoofers and the other drivers will be switched into the circuit, meaning all of the drivers in each speaker are powered by one signal from each channel of a single stereo amp.

For home theater applications, flip the switch to the 3-way plus subwoofer position. In this configuration, each channel powers the 3-way portion of your speakers (tweeter, mid-range, and woofer) while the subwoofers are powered separately by the A2 subwoofer amplifier. The home theater 3-way + option allows the speakers to serve in a modern audio/video surround sound system with extended bass control and response capability.

For two-channel stereo (four-way) installation instructions, turn to page 8.

For multi-channel home theater (three-way plus subwoofer) installation instructions, turn to page 9.

TWO-CHANNEL (STEREO) INSTALLATION

Speaker Placement

For two-channel stereo listening it is recommended that you place your ID1s a few feet from the front wall of the listening area. Generally, two-channel loudspeakers are set between six and twelve feet apart in small to medium listening rooms. Vary this distance until you achieve an evenly distributed soundstage with the center filled in. To optimize bass response, vary the distance of the ID1s from walls and corners, paying special attention to any low frequency nulls in the listening area.

Induction Dynamics drivers are carefully selected and optimized for uniform polar response. This means that the tonal quality of the speakers remains the same off-axis, so it is not necessary to “toe in” the speakers. However, due to variations in the patterns of reflections from one room to another, you may notice a slight improvement in the soundstage at the center listening position if the speakers are “toed in”. Start with approximately 20 degrees each, and experiment with different angles. The best angle will vary with different listening rooms, depending on the pattern of sonic reflections.

Connecting Speakers in Stereo Mode

In normal 2-channel operation, one stereo amplifier is used. For this configuration, the jumper bars on the binding posts should be left in place and the switch on the back of the ID1 should be set to “Four-Way Loudspeaker”. The speaker cable can be connected to either the upper or lower binding posts. Connect the red (positive) amplifier post to the red (positive) speaker post. Connect the black (negative) amplifier post to the black (negative) speaker post. Recommended speaker wire size will depend on the distance from your amplifier to your speaker (see chart on page 4).

MULTI-CHANNEL (HOME THEATER) INSTALLATION

Speaker Placement

The ID1 makes ideal main (left and right channel) speakers for a home theater, while also providing two dual 10" subwoofers powerful enough for a large room. Two ID1s mean a total of four subwoofers. Using multiple subwoofers improves efficiency, lowers distortion, and reduces the incidence of low frequency nulls in the listening area, resulting in a better overall audio experience.

5.1 System

A 5.1 system consists of a front left, front right, surround left, surround right, center channel, and subwoofer channel. A pair of ID1s provide front left, front right, and subwoofer speakers. In a home theater configuration, the center channel should be centered between the left and right front channels and as close to listening height as possible, either above or below the screen (preferably below the screen). The surround channels should be placed to either side of the listening area or behind the listening area at listening height.

6.1 System

A 6.1 system has the same basic channels as a 5.1 system, with the addition of a rear center channel placed directly behind the listening area.

7.1 System

A 7.1 system has the same basic channels as a 5.1 system, with the addition of a left rear surround and right rear surround.

ID1.15 Main Speaker Connection

Remove the jumpers from the binding posts on the back of the ID1 and set the switch to “Three-way + Subwoofer”. Connect the left and right amplifier channels to the top binding posts on the ID1 using normal polarity (red to red and black to black).

Subwoofer Amplifier Interconnect

The ID1 is designed to be used with the A2 subwoofer amplifier (designed and built by Induction Dynamics). The A2 subwoofer amplifier is designed to integrate with audio/video pre-amplifiers and receivers that have their own built-in low-frequency crossover circuits, typically containing optional crossover frequency settings. If the crossover frequency is selectable, the recommended setting for the ID1 is 80 Hz with the subwoofer connected in reverse polarity (see below under Subwoofer Connection).

Using high quality interconnect cables with RCA type terminations, connect “SUBWOOFER OUT” on the audio/video pre-amplifier or receiver to “IN” on the A2.

You may adjust the subwoofer level using the control in the menu of the audio/video pre-amplifier or receiver.

Subwoofer Connection

The jumpers should be removed and the switch set to “Three-way + Subwoofer”. Connect the lower binding posts on the back of the ID1 to the A2 subwoofer amplifier in series using reverse polarity (red to black and black to red).

On the opposite page are diagrams showing alternative methods of connecting the subwoofers, to achieve the in-series, reverse-polarity connections.

Power Connection

Connect the A2 amplifier to a 120 volt, single phase, 60 Hz, grounded power supply using the power cord provided. For best results, use a dedicated power circuit for your amplification equipment.

Method #1

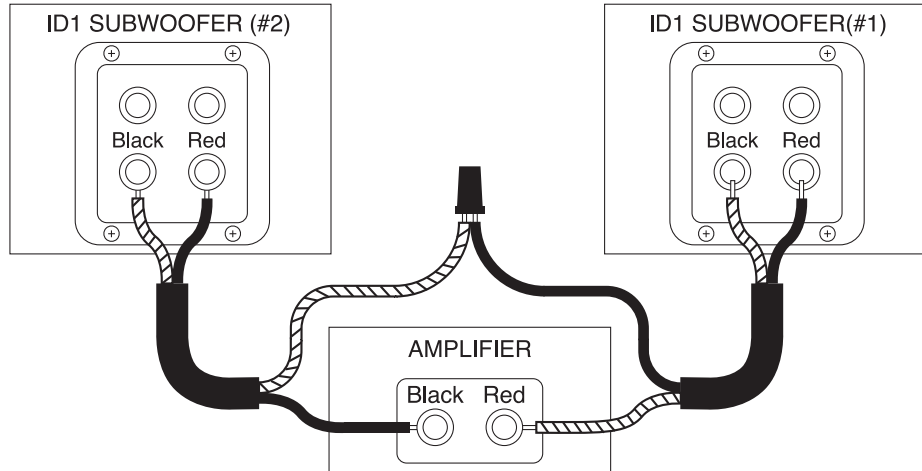

Method #2

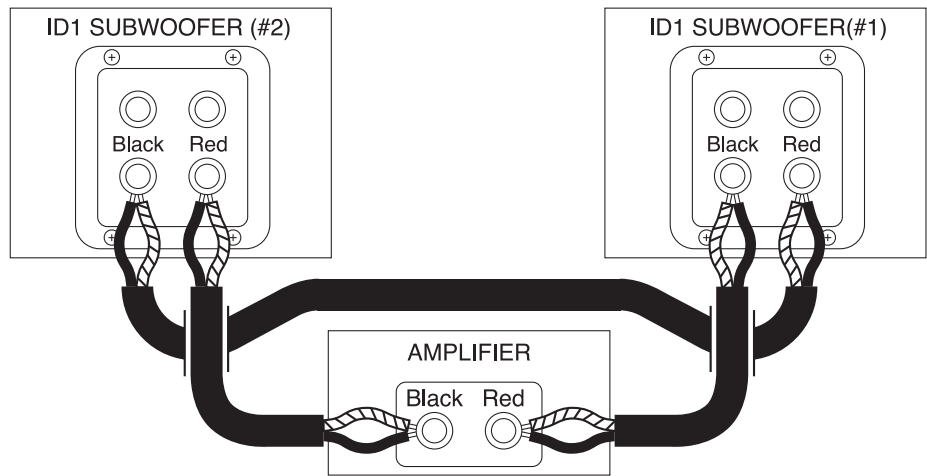

Method #3

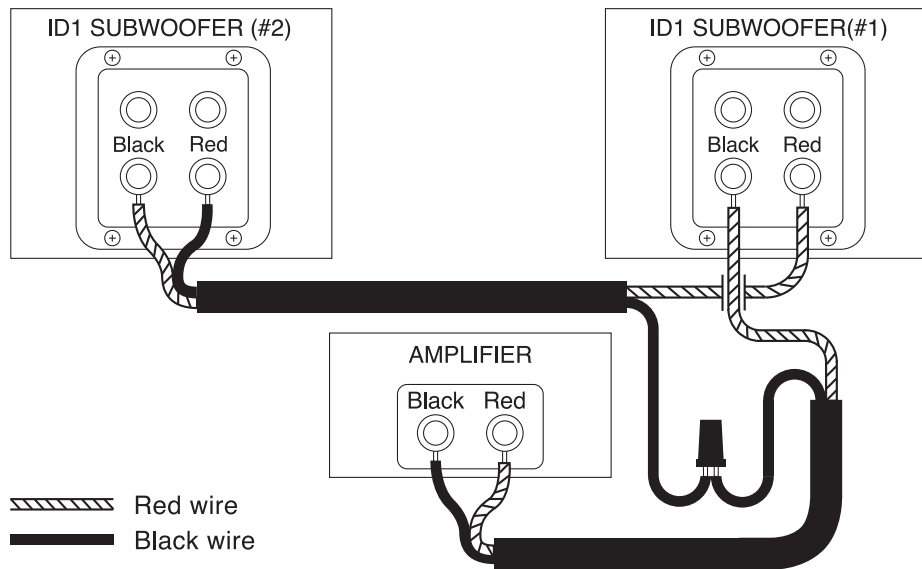

ID1 SPECIFICATIONS

Type:	Dual-purpose 4-way Loudspeaker, switchable to 3-way plus subwoofers.	
Crossover:	Exclusive patented S4X Driver Control Technology.	
	Upper 3-way Loudspeaker	Lower Dual 15" Subwoofer
Crossover Frequencies:	80 (switchable internal), 700, 3,800 Hz	80 Hz switchable internal; 70-80 Hz recommended for external
Nominal Impedance:	8 Ohms	4 Ohms
Frequency Response:	60-22,000 Hz	25-150 Hz
Sensitivity (2.83 V @ 1M):	89 dB	89 dB
SPL (1 W / 1 M):	89 dB	86 dB
Power Handling:	150 W	800 W
Magnetic Shielding:	Yes	No
Tweeter:	1.125" inverted titanium dome	N/A
Midrange:	3" soft dome	N/A
Woofers:	6.5" Kevlar cone with rub- ber surround and cast frame	N/A
Subwoofer:	N/A	(2) 10" mica-graphite poly cones with rubber surrounds and cast frames
Binding Posts:	Gold-plated; #4 AWG Max	Gold-plated; #4 AWG Max
Enclosure:	Ported	Sealed
Optional Accessories:	N/A	A2 subwoofer amplifier

A2 SPECIFICATIONS

Type:	Class AB Bipolar Subwoofer Amplifier
Driver Control:	Patented non-distorting, frequency-selective excursion limiter
Frequency Response:	20 Hz - 20 kHz, +/- 0.25 dB
Harmonic Distortion:	< 0.078% (@ 1 kHz, 1 Watt)
Voltage Gain (dB) S/N:	36 dB (internally switchable to 26 dB)
Damping Factor:	95 dBA
Input Impedance:	400 Ohms @ 60 Hz
Output Load:	10 K Ohms (2.5 minimum)
Power Output (Continuous) 2.5 Ohms / 4 Ohms / 8 Ohms	700 Watts / 520 Watts / 300 Watts
Inputs:	1 RCA (RCA plus XLR optional)
Output Binding Posts:	Gold Plated; #10 AWG max, or Banana Plugs
Power Requirements:	120 v AC, 6A slow-burn fuse
Auto On/Off	Auto power down if no signal for 20 minutes (turn-on sensitivity 2 mv)

WARRANTY

Induction Dynamics, Inc. warrants the ID1 and A2 subwoofer amplifier against defects in materials and workmanship for a period of seven years from the date of original retail purchase. Induction Dynamics, Inc. will repair or replace any ID1 or A2 that does not meet this warranty.

This warranty may be registered by mailing a copy of the retail sales receipt to Induction Dynamics, Inc. at the address below. Please write the serial number along with the name and address of the retailer from whom you purchased the speaker(s) and/or amplifier(s). This may be done at the time of purchase or before requesting repair service under this warranty.

To obtain repair service, call or write to Induction Dynamics, Inc. at the phone number or address below. You will be given a return authorization number. Please mark this number clearly on the outside of the package(s) for identification. Packages that are not marked with a return authorization number on the outside may not be accepted by Induction Dynamics, Inc. Please pack each ID1 or A2 in a substantial shipping container with plenty of protective foam. If possible, use the original shipping container and packing material. For repairs covered by and performed under this warranty, Induction Dynamics, Inc. will pay for the return shipping charges. This warranty covers defects in materials and workmanship, and does not cover damage or failure resulting from accident, misuse, or shipment. The warranty is void if the ID1 or A2 is serviced or altered by anyone other than Induction Dynamics, Inc. the sole remedy for breach of this warranty shall be repair or replacement.

Limits and Exclusions: There are no warranties except as mentioned above. Neither Induction Dynamics, Inc. nor anyone else who has been involved in the creation, production, or sale of this product shall be liable for any direct, indirect, consequential or accidental damages arising out of the use or inability to use this product, or arising out of breach of this warranty. Induction Dynamics, Inc. makes no other warranties, express or implied, including without limitation warranties of merchantability or fitness for a particular purpose. There are no warranties that extend beyond the description on the face hereof.

Induction Dynamics
Customer Service Department
8005 W. 110th St., Suite 208
Overland Park, KS 66210
USA

Phone: 855.663.5600
Fax: 913.663.3200

CONTACTS

Manufacturer Information

If you have any questions, contact Induction Dynamics by phone at 855-663-5600, 8:00 a.m.- 5:00 p.m. CST, fax at 913-663-3200, email at sales@inductiondynamics.com, or write to:

Induction Dynamics
Customer Service Department
8005 W. 110th St., Suite 208
Overland Park, KS 66210
USA

Note: Please do not ship your loudspeaker for service without obtaining prior approval and return authorization number. See warranty for further information.

Retailer Information

To help simplify your record keeping, please fill out the following information about the retailer you bought your Induction Dynamics products from. Additionally, you may staple, tape, or glue a copy of your receipt to the next page.

Retailer name (company or individual): _____

Address: _____

City: _____

State: _____

Zip or Postal code: _____

Phone: _____

Email: _____

Date of purchase: _____

Serial number: _____

To simplify your record keeping,
please glue, staple, or tape your receipt
to this page.

Audio Perfection Realized



INDUCTION DYNAMICS®

8005 W. 110th Street, Suite 208
Overland Park, KS 66210
Tel: (855) 663-5600
Fax: (913) 663-3200
www.inductiondynamics.com

© Induction Dynamics®, August 2013