

**data**video

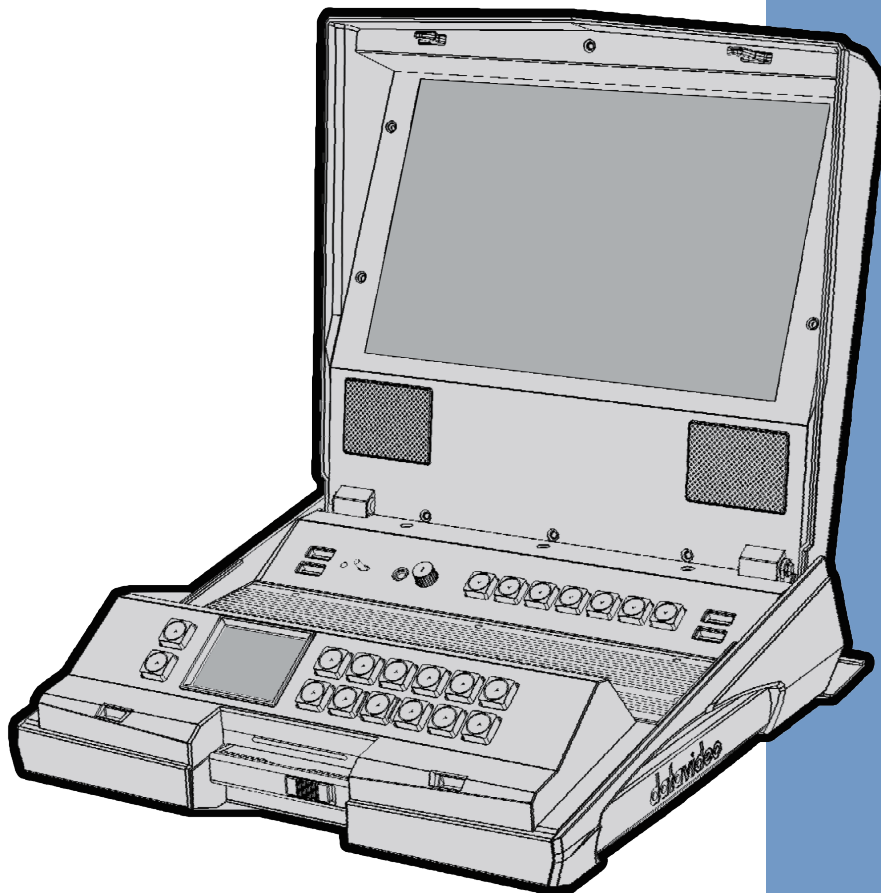

**FIELD SIDE HAND  
CARRY RECORDER  
HRS-30**

**Instruction Manual**

[www.datavideo.com](http://www.datavideo.com)

# Table of contents

FCC Compliance Statement .....	4
Warnings and Precautions .....	4
Warranty .....	5
Disposal.....	5
Unpacking the HRS-30.....	6
HRS-30 Top View .....	6
HRS-30 & Battery.....	7
Rear Panel.....	8
Monitor Operation Keyboard.....	9
Monitor Menu Options .....	10
PICTURE .....	10
FUNC .....	11
SETUP .....	12
ADVANCED .....	13
Recorder Operation Keyboard.....	14
Recorder Display Panel Status .....	16
Recorder Menu Key Options .....	17
<b>TOOL</b> .....	17
FIRMWARE REVISION.....	17
ERASE THIS BIN.....	18
FORMAT MEDIA .....	19
UPGRADE FIRMWARE .....	20
UN-LOCK MEDIA.....	21
<b>SETUP</b> .....	22
RECORD SETUP.....	22
PLAY SETUP .....	25
SYSTEM SETUP .....	27
SAVE SETUP .....	30
RECALL SETUP .....	31
<b>STATUS</b> .....	32
Assemble 2.5" HDD in Removable Rack.....	33
Connecting the 2.5" HDD to PC .....	34
Connecting the 2.5" HDD to MAC.....	35
Q & A.....	36
HRS-30 Error Codes .....	37
HRS-30 RS-232 Control Command .....	38
Example HRS-30 Set Up .....	42
RJ-45 Pin Define .....	44
Dimensions .....	44
Specifications .....	45
Service & Support .....	50

**Disclaimer of Product & Services**

The information offered in this instruction manual is intended as a guide only. At all times, Datavideo Technologies will try to give correct, complete and suitable information. However, Datavideo Technologies cannot exclude that some information in this manual, from time to time, may not be correct or may be incomplete. This manual may contain typing errors, omissions or incorrect information. Datavideo Technologies always recommend that you double check the information in this document for accuracy before making any purchase decision or using the product. Datavideo Technologies is not responsible for any omissions or errors, or for any subsequent loss or damage caused by using the information contained within this manual. Further advice on the content of this manual or on the product can be obtained by contacting your local Datavideo Office or dealer.

## FCC Compliance Statement

This device complies with part 15 of the FCC rules. Operation is subject to the following two conditions:

1. This device may not cause harmful interference, and
2. This device must accept any interference received, including interference that may cause undesired operation.

## Warnings and Precautions



1. Read all of these warnings and save them for later reference.
2. Follow all warnings and instructions marked on this unit.
3. Unplug this unit from the wall outlet before cleaning. Do not use liquid or aerosol cleaners. Use a damp cloth for cleaning.
4. Do not use this unit in or near water.
5. Do not place this unit on an unstable cart, stand, or table. The unit may fall, causing serious damage.
6. Slots and openings on the cabinet top, back, and bottom are provided for ventilation. To ensure safe and reliable operation of this unit, and to protect it from overheating, do not block or cover these openings. Do not place this unit on a bed, sofa, rug, or similar surface, as the ventilation openings on the bottom of the cabinet will be blocked. This unit should never be placed near or over a heat register or radiator. This unit should not be placed in a built-in installation unless proper ventilation is provided.
7. This product should only be operated from the type of power source indicated on the marking label of the AC adapter. If you are not sure of the type of power available, consult your Datavideo dealer or your local power company.
8. Do not allow anything to rest on the power cord. Do not locate this unit where the power cord will be walked on, rolled over, or otherwise stressed.
9. If an extension cord must be used with this unit, make sure that the total of the ampere ratings on the products plugged into the extension cord do not exceed the extension cord rating.
10. Make sure that the total amperes of all the units that are plugged into a single wall outlet do not exceed 15 amperes.
11. Never push objects of any kind into this unit through the cabinet ventilation slots, as they may touch dangerous voltage points or short out parts that could result in risk of fire or electric shock. Never spill liquid of any kind onto or into this unit.
12. Except as specifically explained elsewhere in this manual, do not attempt to service this product yourself. Opening or removing covers that are marked "Do Not Remove" may expose you to dangerous voltage points or other risks, and will void your warranty. Refer all service issues to qualified service personnel.
13. Unplug this product from the wall outlet and refer to qualified service personnel under the following conditions:
  - a. When the power cord is damaged or frayed;
  - b. When liquid has spilled into the unit;
  - c. When the product has been exposed to rain or water;
  - d. When the product does not operate normally under normal operating conditions. Adjust only those controls that are covered by the operating instructions in this manual; improper adjustment of other controls may result in damage to the unit and may often require extensive work by a qualified technician to restore the unit to normal operation;
  - e. When the product has been dropped or the cabinet has been damaged;
  - f. When the product exhibits a distinct change in performance, indicating a need for service.

# Warranty

## Standard Warranty

- Datavideo equipment are guaranteed against any manufacturing defects for one year from the date of purchase.
- The original purchase invoice or other documentary evidence should be supplied at the time of any request for repair under warranty.
- The product warranty period begins on the purchase date. If the purchase date is unknown, the product warranty period begins on the thirtieth day after shipment from a Datavideo office.
- Damage caused by accident, misuse, unauthorized repairs, sand, grit or water is not covered under warranty.
- Viruses and malware infections on the computer systems are not covered under warranty.
- Any errors that are caused by unauthorized third-party software installations, which are not required by our computer systems, are not covered under warranty.
- All mail or transportation costs including insurance are at the expense of the owner.
- All other claims of any nature are not covered.
- Cables and batteries are not covered under warranty.
- Warranty only valid in the country or region of purchase.
- Your statutory rights are not affected.

## Three Year Warranty

- All Datavideo products purchased after July 1st, 2017 are qualified for a free two years extension to the standard warranty, providing the product is registered with Datavideo within 30 days of purchase.
- Certain parts with limited lifetime expectancy such as LCD panels, DVD drives, Hard Drive, Solid State Drive, SD Card, USB Thumb Drive, Lighting, Camera module, PCIe Card are covered for 1 year.
- The three-year warranty must be registered on Datavideo's official website or with your local Datavideo office or one of its authorized distributors within 30 days of purchase.



## Disposal

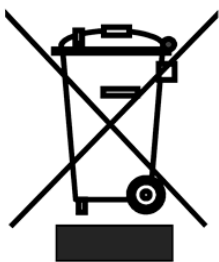

### For EU Customers only - WEEE Marking

This symbol on the product or on its packaging indicates that this product must not be disposed of with your other household waste. Instead, it is your responsibility to dispose of your waste equipment by handing it over to a designated collection point for the recycling of waste electrical and electronic equipment. The separate collection and recycling of your waste equipment at the time of disposal will help to conserve natural resources and ensure that it is recycled in a manner that protects human health and the environment. For more information about where you can drop

off your waste equipment for recycling, please contact your local city office, your household waste disposal service or the shop where you purchased the product.



**CE Marking** is the symbol as shown on the left of this page. The letters "CE" are the abbreviation of French phrase "Conformité Européene" which literally means "European Conformity". The term initially used was "EC Mark" and it was officially replaced by "CE Marking" in the Directive 93/68/EEC in 1993. "CE Marking" is now used in all EU official documents.

## Unpacking the HRS-30

Place the HRS-30 on a level desk or surface. The carry handle will be at the right side facing the operator's position.

To open the HRS-30 monitor lid slide the thumb catches in the direction shown to their outer most position. Then lift the monitor lid upwards away from the keyboard and carry handle.

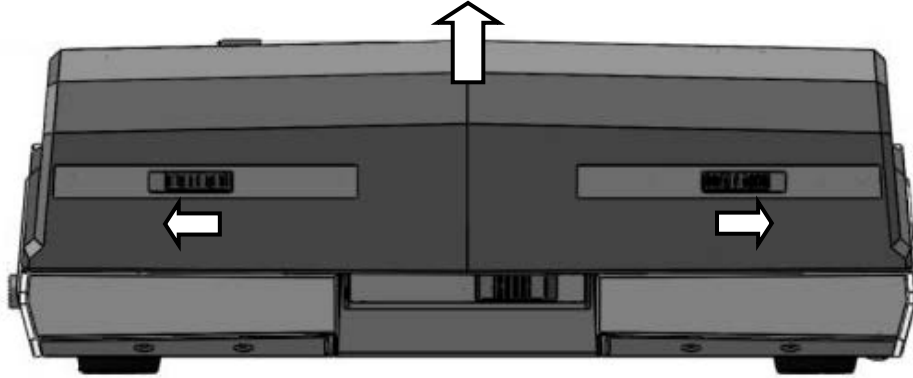

## HRS-30 Top View

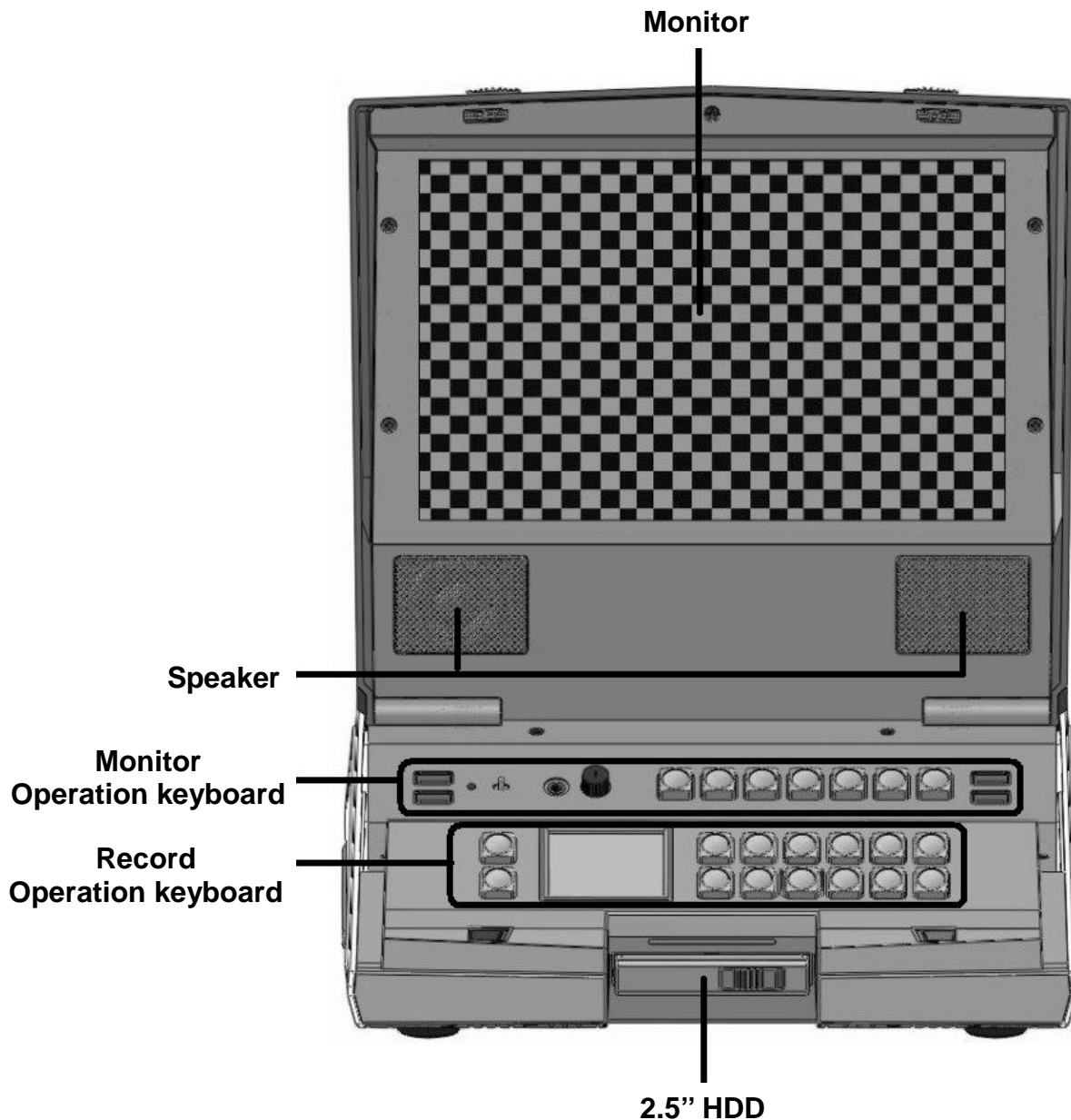

## HRS-30 & Battery

The HRS-30 can be powered from a standard V-Mount battery connection or mains power. This enables you to power the HRS-30 using an existing camera battery.

### HRS-30: with V-mount Battery Plate

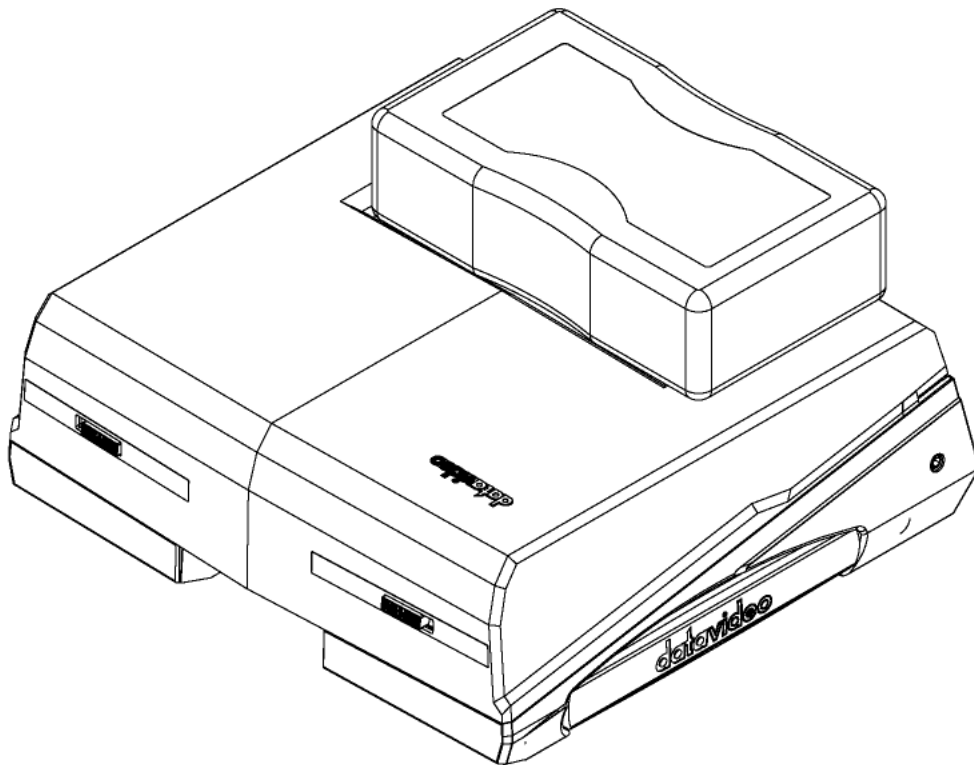
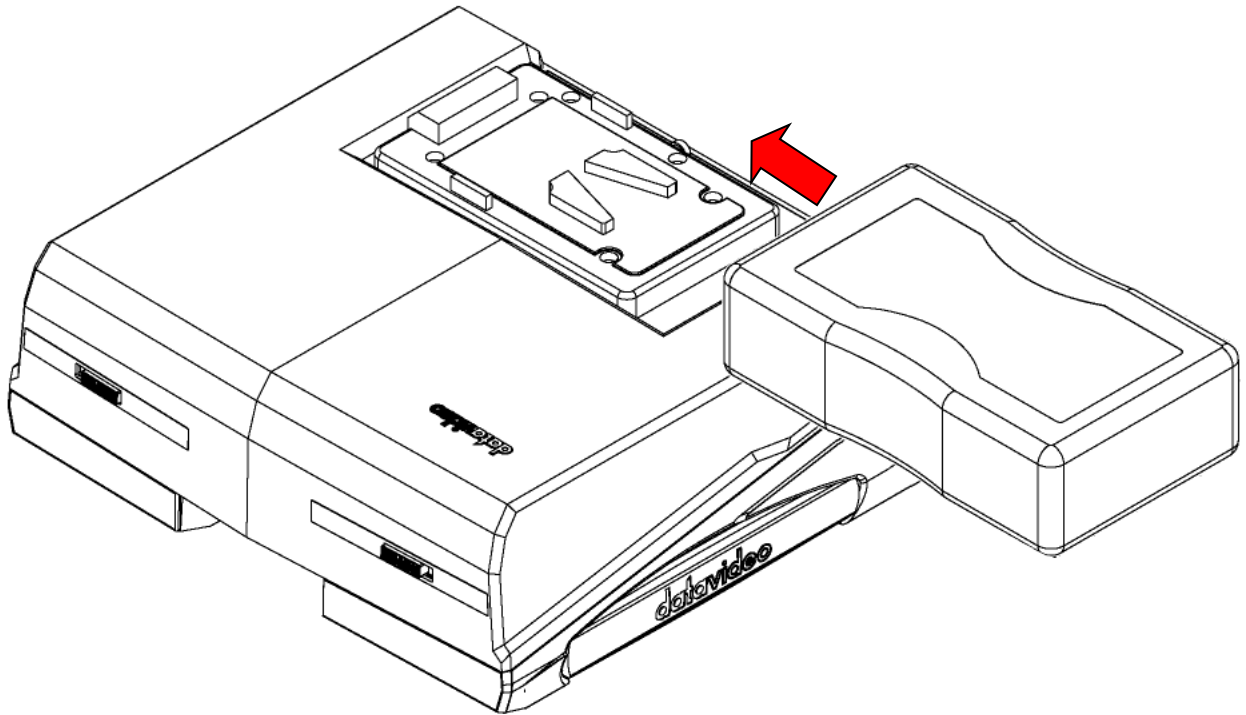

# Rear Panel

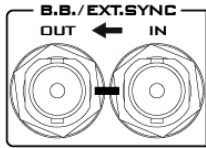
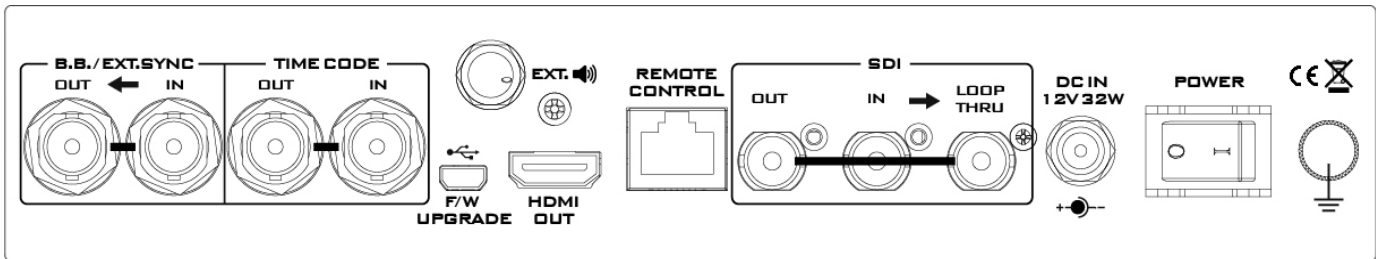

## Black Burst / Loop Through Out

Black Burst / Loop Through Out can be used as a video reference source when synchronization other devices to the HRS-30.

**Note:** User needs to add a 75 ohm terminator if this is the latest device of the Black Burst signal chain.

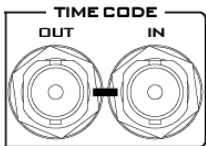

## Time Code Signal IN /OUT & Loop through OUT

HRS-30 can use an internal or external time code source.

In **RECORD** state, the source time code will through to output.

In **PLAY** state, the output time code source is from the HRS-30 playing file.



## Stereo Phone Jack Plug

For audio output. The phone volume is controlled by the Audio Level Adjustments (on the Monitor Operation Keyboard).

When this phone jack connect earphone, the HRS-30 speaker function still working.



## Mini USB

This is for Recorder Operation keyboard firmware upgrade purpose.



## HDMI OUT

HDMI output ports for connecting to HDMI external devices.



## Remote Control Port

Enable / Disable via user interface, please see the **REMOTE CONTROL** (Page 26) for more details.

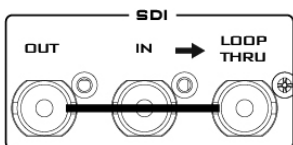

## HD- SDI IN / OUT & Pass-through OUT Connectors

4:2:2 SDI video data supports SMPTE 292M standard at 1.5Gbps.

DC IN  
12V 32W



## DC IN Socket

DC input socket connect the supplied 12V PSU to this socket.

POWER

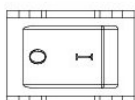

## Power On/Off Switch

Switches the HRS-30 power ON / OFF.



## Grounding Terminal

When connecting this unit to any other component, make sure that it is properly grounded by connecting this terminal to an appropriate point. When connecting, use the socket and be sure to use wire with a cross-sectional area of at least 1.0 mm<sup>2</sup>.



# Monitor Operation Keyboard

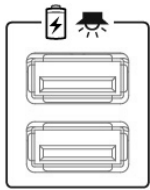
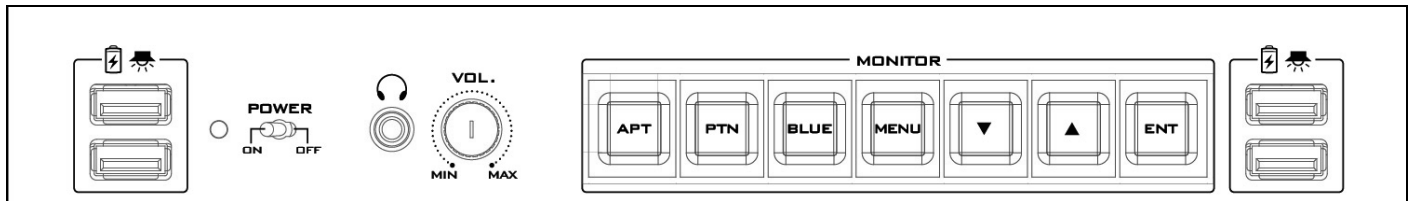

## USB Port

USB ports for LED Light power supply also can supply USB power charge.

USB ports only support 5V / 500mA.

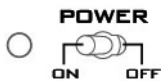

## Power Switch

Switches the monitor power On / Off.



## Stereo Phone Jack Plug

For stereo headphones. The headphone volume is controlled by the Audio Level Adjustments.

When this phone jack connected earphone, the HRS-30 speaker function will disable.



## Audio Level Adjustments

Allow you to adjust the headphones volume.



## Aspect Ratio Button

Sets the LCD aspect ratio to 4:3, 16:10, or 16:9



## PATTERN

The PATTERN button will generate colour bars on the screen. Press the PATTERN button again to return normal output.



## BLUE

Press this button to eliminate the red and green component of input signals. Only the blue component of an input is displayed on the screen. This allows adjustments of chroma and phase. (Phase adjustment is effective with NTSC signals).

This button have other one function is exit the MENU mode.



## MENU

Calls up the on-screen adjustment menu. Please see the **Monitor Menu Options** (page 8) for more details.



## UP / DOWN

Navigate the on-screen menu and set the functions & levels.



## ENTER





Confirms the new settings or return to the default state.

# Monitor Menu Options

## PICTURE



Step 1. Press the  button into the monitor system setting mode.

PICTURE				
BRIGHTNESS		50		
CONTRAST		50		
SATURATION		50		
TINT		50		
COLOR TEMP		>>		

▼:Down ▲:Up Menu:Esc Blue:Exit

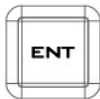

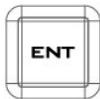

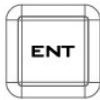
Step 2. Press  button into the **PICTURE** setting position.

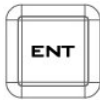

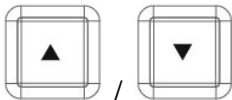
Step 3. Press  button again into the **BRIGHTNESS** setting position.



Step 4. Press  /  button to setting the **BRIGHTNESS** values from 0~100

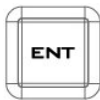

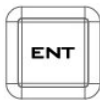
Step 5. Press  button to save your setting and return to the **PICTURE** setting menu.

**Note 1:** To select a different setting (**CONTRAST, SATURATION, TINT, COLOR TEMP**) use the

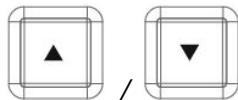

*buttons follow the same procedure to set the others values.*

**Note 2:** **BRIGHTNESS CONTRAST, SATURATION** and **TINT** these four modes, the value all the same as 0~100.

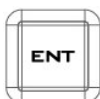

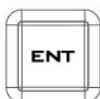
Step 6. Press  button into the **COLOR TEMP** setting.

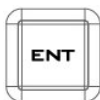





Step 7. Press  button again to select the **COLOR TEMP** mode (**USER/ 5400 / 6500/ 7500 / 9300**).

Step 8. In **USER** mode, you can set RED, GREEN and BLUE colour. Those three modes value all the same as 0~255.

# FUNC



**Step 1.** Press the  button two times move to the monitor **FUNC** setting mode.

<b>FUNC</b>	   
CENTER MARK	OFF
SAFETY ZONE	OFF
4 : 3 SCREEN	OFF
CINEMA ZONE	OFF
▼:Down   ▲:Up   Menu:Esc   Blue:Exit	



**Step 2.** Press  button into the **FUNC** setting position.



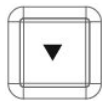

**Step 3.** Press  button again to setting the **CENTER MARK ON/OFF** on the screen.



**Step 4.** Press  /  button moving to the **SAFETY ZONE** setting.



**Step 6.** Press  button to setting the **SAFETY ZONE** range (80, 90 or OFF).

**Note:** To select a different setting (**4:3 SCREEN, CINEMA ZONE**) use the  /  buttons. Follow the same procedure to set the others status.

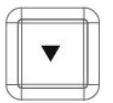
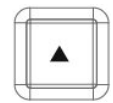

# SETUP



**Step 1.** Press the  button three times move to the monitor **SETUP** setting mode.

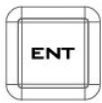
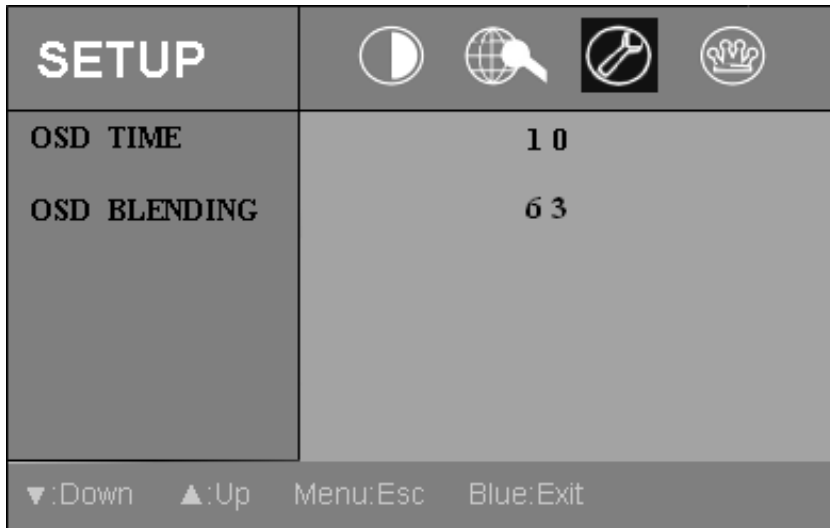

**Step 2.** Press  button move to the **SETUP** setting position.



**Step 3.** Press  button again into to the **OSD TIME** setting position.

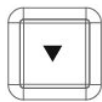

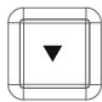
**Step 4.** Press  /  button to setting the OSD display on screen time (value from 5~60 SECONDS).



**Step 5.** Press  button to save your setting and return to the **SETUP** setting menu.

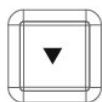

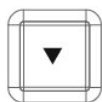
**Step 6.** Press  /  button move to the **OSD BLENDING** setting position.



**Step 7.** Press  button into to the **OSD BLENDING** setting position.

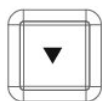

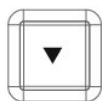
**Step 8.** Press  /  button to setting the **OSD BLENDING** value (0~63).





**Step 9.** Press  button to save your setting and return to the **SETUP** setting menu.

## ADVANCED

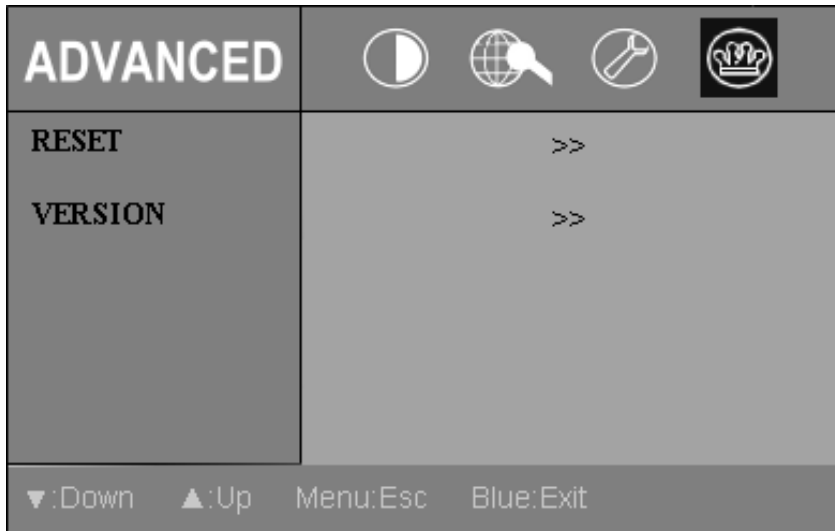

**Step 1.** Press the  button four times into the monitor **ADVANCED** setting mode.



**Step 2.** Press  button into the **RESET** setting position.



**Step 3.** Press  button again which will return all the settings of the monitor to the factory defaults.



**Step 4.** Press  button into the **ADVANCED** setting mode.

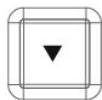

**Step 5.** Press  /  button move to the **VERSION** setting position.



**Step 6.** Press  button, the version information will display on screen.



**Step 7.** Press  button exit the setting mode.

# Recorder Operation Keyboard

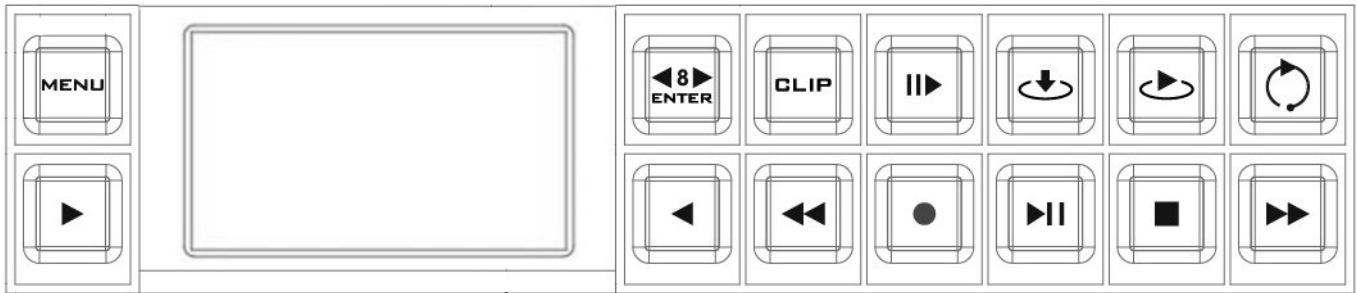

## Menu Button



This calls up the menu display which is navigated using the  /  Soft Keys.



## Enter or Skip 8 sec.

**Enter Key:** Confirm your **Recorder Operation** select, display on 2" LCD panel.



In order to activate Skip 8 sec. function while HRS-30 is playing a video clip, press

**Skip 8 sec.** button and then press  /  Soft Keys to skip forward by 8~10 seconds or backward 8 ~ 10 seconds (depending on the recorded format).



## CLIP Selection

Press the "CLIP" button to activate the function "skip to the next CLIP or previous CLIP."

In HRS-30 play state, press **CLIP** button and then press  /  Soft Keys skip to next or last CLIP.



## Slow Motion Play Back

In order to activate Slow Motion Playback while HRS-30 is playing a video clip, press

 key, and then press  /  Soft Keys to slow forward / slow rewind of 1/3X, 1/6X, 1/9X, 1/12X.

**Note:** IF the format of the file being played is **I-Frame only**, the forward & rewind speed will have an additional 1/2 option.

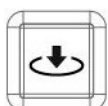

## Mark In (I-frame only)

Press this button to set a cue point during play or record. This memorized cue point can be recalled by "Playback From Mark In" during playback.

**Note:** When you press this button, the current time code will turn red for 3 seconds on the 2" LCD panel.



## Playback From Mark In (I-frame only)

Press this button to quick review video footage start from memorized mark-in point.

**Note:** The mark-in review will start from the location 5 seconds prior to actual mark-in point to compensate delay between eye sight and hand motion.



### Re-Playback

Press this button once: Re-Playback from last 15 seconds of the last CLIP to review.

Press this button two times: Re-Playback from last 15 seconds of the last CLIP to review.

- IDLE Mode: Re-Playback from the last 15 seconds of the Last clip in the current BIN.

- PLAY Mode: Skip back by 8~10 SEC.

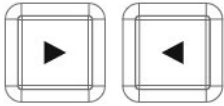

### PREV / NEXT Soft Keys

These two buttons are not only for skipping to Previous/Next clip but also for other functions, so these two buttons are also known as "Soft Keys."



### Rew Button

In playback state, this button will operate as **Fast Rewind** Button.

During Fast Rewind, press  /  Soft Keys to select rewind speed (x1, x3, x6, x9, and x12).

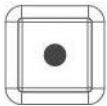

### Record Button

To start recording press the Record Button and Play Button simultaneously.

**Note1:** Unit will not record if no video signal is present.

**Note2:** In HRS-30 play state, press Record button, 2" LCD Display Panel will show the **FILE FORMAT** and **BIN FILE LENGTH** information; press Record button again will return to normal.



### Play / Pause Button

Starts play file, or pauses play, the status will be displayed on the 2" LCD Display Panel.

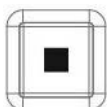

### Stop Button

Stops playback or record.

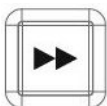

### Fwd Button

In playback state, this button will operate as Fast Forward Button.

During Fast Forward, press  /  Soft Keys to select fast forward speed (x1, x3, x6, x9, and x12).

# Recorder Display Panel Status

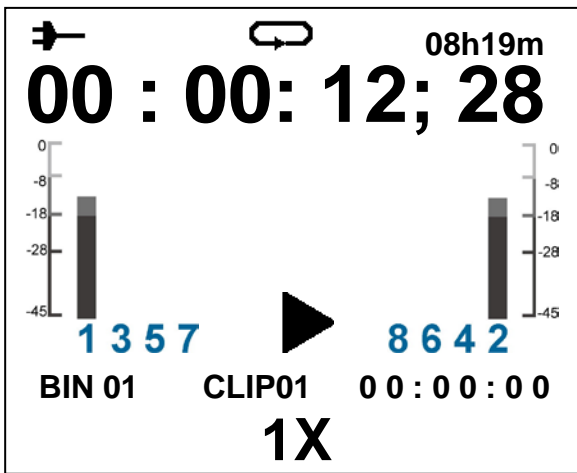

SYMBOL	DESCRIPTION
	Type A: connect DC power indication
	Type B: connect battery power indication
	Loop Playback indicator
08h19m	Remaining Recording Space in Hours and Minutes
00:00:12;28	Current Time Code or total length of CLIP
	Eight channel audio meters 1357 – Channels 1, 3, 5, 7 8642 – Channels 2, 4, 6, 8
	Record, Pause, FWD, REV, Play, and Stop indication
1X 3X 6X 9X 12X 1/2X 1/3X 1/6X 1/9X 1/12X	Fast Forward or Fast Rewind speeds; Slow Forward or Slow Rewind speeds
	Skip forward by approximately 8 seconds or Skip back by approximately 8 seconds.
BIN 01	Current BIN number
CLIP01	Current CLIP number



# Recorder Menu Key Options

## TOOL

### FIRMWARE REVISION

Display the HRS-30 firmware information: CODEC, HOST, REC...etc.

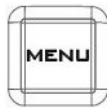

**Step 1.** Press the (MENU) button into the menu mode.

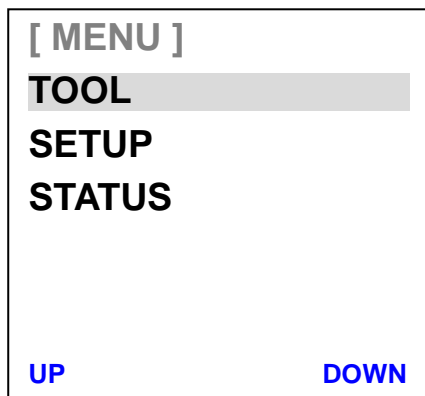

**Step 2.** Press the (ENTER) button into the **TOOL** menu.

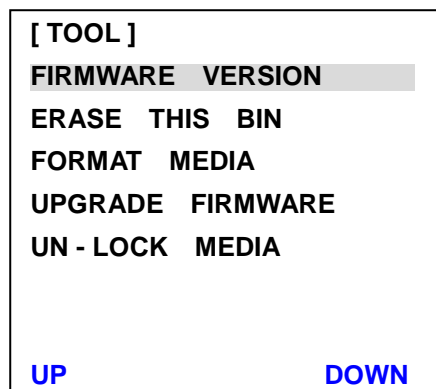

**Step 3.** Press the (ENTER) button again to see the **FIRMWARE VRESION**.

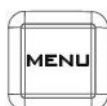
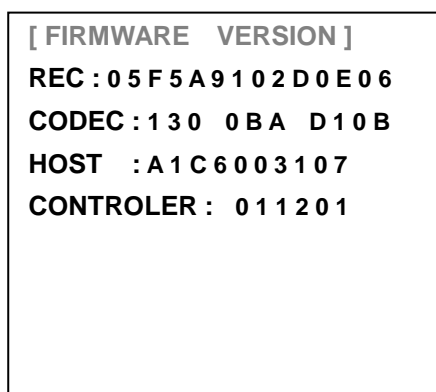

**Step 4.** Press the (MENU) button exit the **FIRMWARE VERSION** mode.

## ERASE THIS BIN

ERASE THIS BIN is used for deleting individual bins from the HRS-30.



**Step 1.** Press the (MENU) button into the menu mode.



**Step 2.** Press the (ENTER) button into the **TOOL** menu.

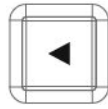
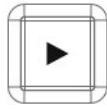

**Step 3.** Press the (UP) button / (DOWN) button select to the **ERASE THIS BIN** menu.

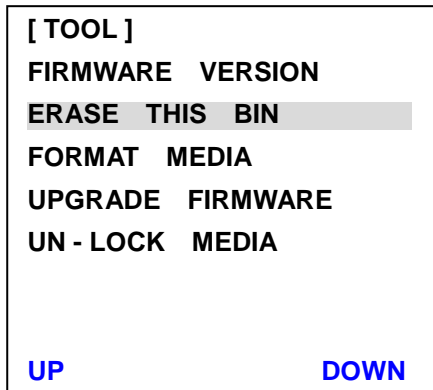

**Step 4.** Press the (ENTER) button into the **ERASE THIS BIN** menu.

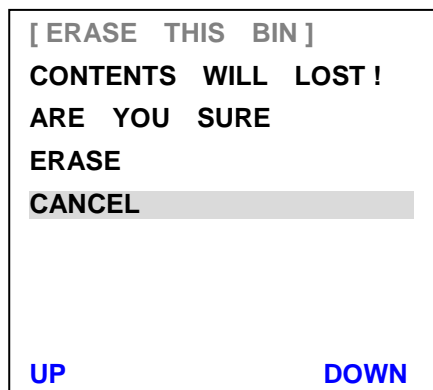

**Step 5.** Press the (UP) button move to the **ERASE** options position.



**Step 6.** Press the (ENTER) button to erase the selected bin - The bin duration will return to 00:00:00:00.

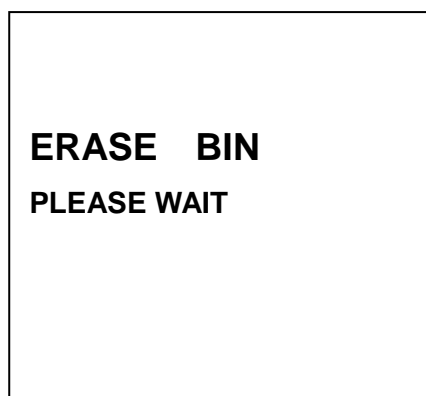

## FORMAT MEDIA

Format Media will remove all bins from the hard drive.

**Step 1.** Press the  (MENU) button into the menu mode.

**Step 2.** Press the  (ENTER) button into the **TOOL** menu.

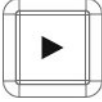
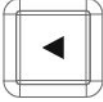
**Step 3.** Press the  (UP) button /  (DOWN) button select to the **FORMAT MEDIA** menu.

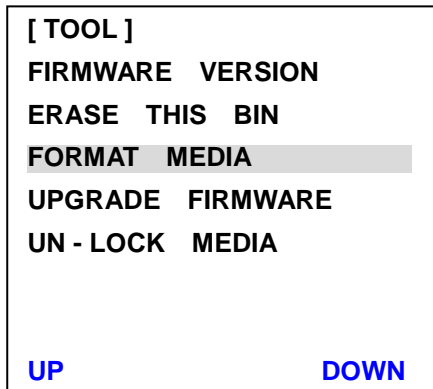

**Step 4.** Press the  (ENTER) button into the **FORMAT MEDIA** menu.

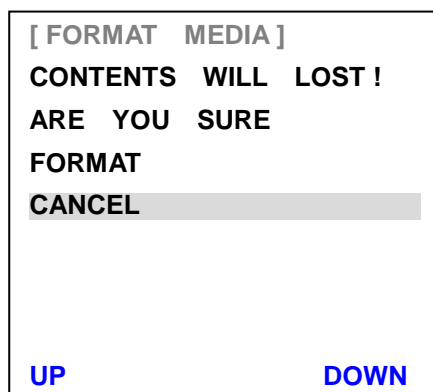

**Step 5.** Press the  (UP) button move to the **FORMAT** options position.

**Step 6.** Press the  (ENTER) button to format the selected bin - The bin duration will return to 00:00:00:00  
After a few seconds the HRS-30 will return to normal.

**NOTE:** When your 2.5" HDD contains media, the first time you connect the HDD to computer, the computer needs about 20 seconds to link this HDD.

## UPGRADE FIRMWARE



HRS-30 has two parts firmware need to Update:

### Part 1: Recorder Keyboard

- Step 1. Use the USB (Type A to Mini USB) cable to the HRS-30 rear side mini USB port, and connect to your computer.
- Step 2. Power on the HRS-30, a new USB disk should appear on the computer
- Step 3. Copy firmware.bin and overwrite the firmware file in the destination file folder.
- Step 4. Safe remove the USB disk.

### Part 2: Recorder Main Board

- Step 1. Select the FORMAT MEDIA function to format 2.5" HDD.
- Step 2. Turn off the HRS-30 power after format media is done.
- Step 3. Move out the 2.5"HDD from HRS-30.
- Step 4. Connect it to your computer.
- Step 5. Copy the firmware update file (**flash.bin**) to the root directory of 2.5" HDD.
- Step 6. Safe remove the 2.5" HDD cable.
- Step 7. Insert the 2.5" HDD in the HRS-30 and select the UPGRADE FIRMWARE option and follow the instructions.

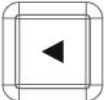
- Press the  (MENU) button into the menu mode.
- Press the  (ENTER) button into the **TOOL** menu.
- Press the  (UP) button /  (DOWN) button select to the **UPGRADE FIRMWARE** menu.

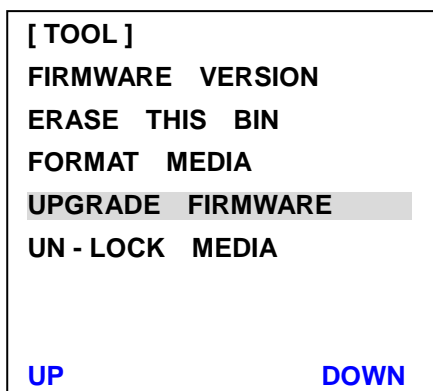

- Press the  (ENTER) button to upgrade the HRS-30 firmware.
- Reboot the HRS-30.

**\*NOTE:** The process will take approximately few minutes to complete.

**\*NOTE:** Please don't "**UNLOCK MEDIA**" during upgrade firmware process.

## UN-LOCK MEDIA

[After you record file at HRS-30, the 2.5" HDD format become read only. To set disk writable please do UN-LOCK MEDIA.](#)



**Step 1.** Press the (MENU) button into the menu mode.



**Step 2.** Press the (ENTER) button into the **TOOL** menu.

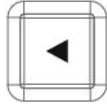
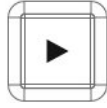

**Step 3.** Press the (UP) button / (DOWN) button select to the **UN-LOCK MEDIA** menu.

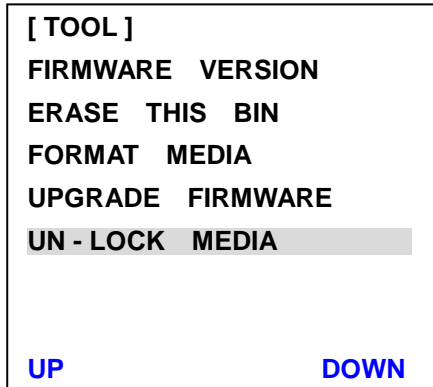

**Step 4.** Press the (ENTER) button to unlock media files.

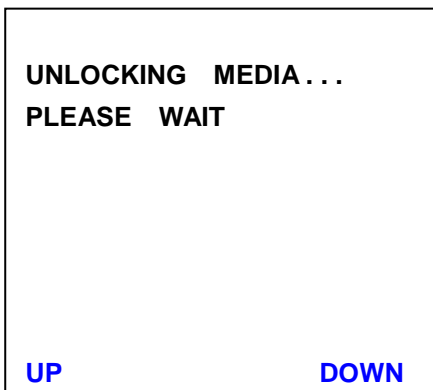

# SETUP

## RECORD SETUP



Step 1. Press the (MENU) button into the menu mode.

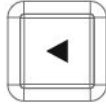
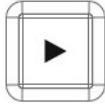

Step 2. Press the (UP) button / (DOWN) button select to the **SETUP** menu.

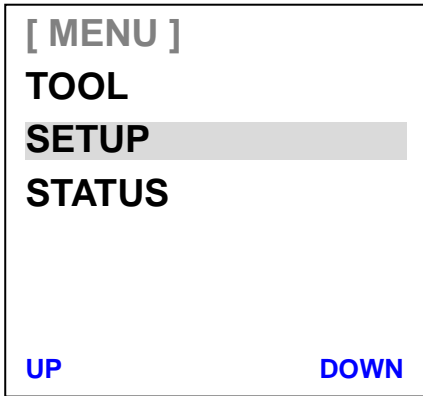

Step 3. Press the (ENTER) button into the **SETUP** menu.

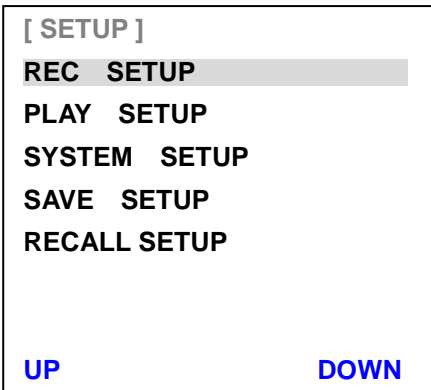

Step 4. Press the (ENTER) button into the **REC SETUP** menu.

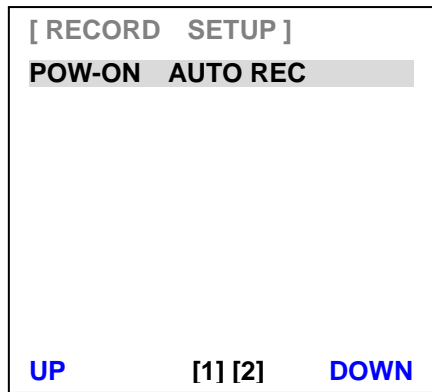
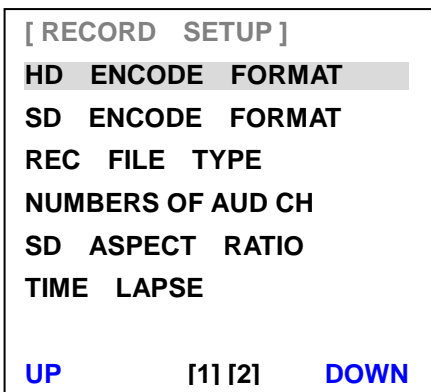

**Step 5.** Press the  (UP) button /  (DOWN) button to select the **HD ENCODE FORMAT / SD ENCODE FORMAT / REC FILE TYPE / REC CHANNEL NUM / SD ASPECT RATIO / TIME LAPSE / PWR-ON AUTO REC** menu.

**Step 6.** Press the  (ENTER) button into the **HD ENCODE FORMAT / SD ENCODE FORMAT / REC FILE TYPE / REC CHANNEL NUM / SD ASPECT RATIO / TIME LAPSE / PWR-ON AUTO REC** menu.

**HD ENCODE FORMAT** - Setting the HD video encode format to 100M I FRAME ONLY or 125M I FRAME ONLY (encode Intra frame only).

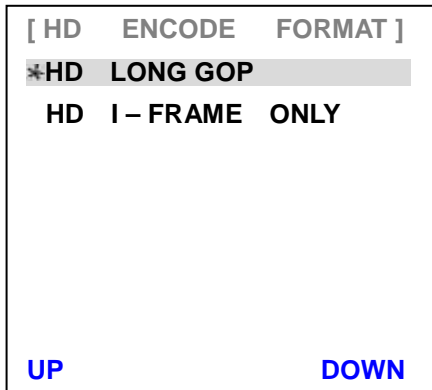

**SD ENCODE FORMAT** - Setting the SD video encode format to 25M I FRAME ONLY or 50M I FRAME ONLY (encode Intra frame only).

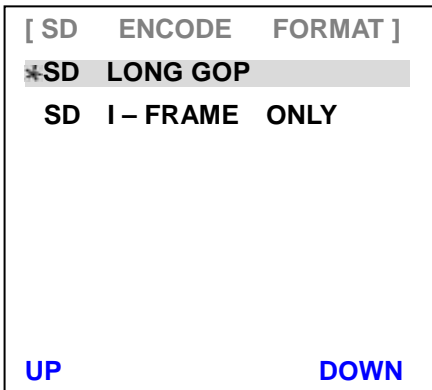

**REC FILE TYPE** - Setting the record file type is MXF or MOV.

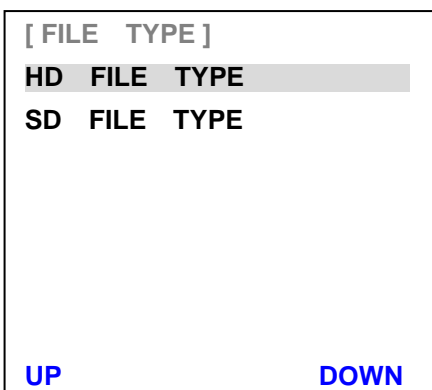

**NUMBERS OF AUD CH - Audio channel selection: User can select to record 2, 4 or 8 audio channels.**

[ NUMBERS OF AUD CH ]

\*2CH

4CH

8CH

UP DOWN

**SD ASPECT RATIO - Sets the SD aspect ratio to 16:9 or 4:3.**

[ SD ASPECT RATIO ]

\*4 : 3

16 : 9

UP DOWN

**TIME LAPSE - Setting the TIME LAPSE ON/ OFF.**  
Setting the TIME LAPSE FRAME RATE (1 frame / 1 sec).  
Setting the TIME LAPSE CYCLE (y frame per x sec).

[ TIME LAPSE ]

TIME LAPSE ON / OFF

TIME LAPSE CYCLE

UP DOWN

**PWR-ON AUTO RECORD - Setting the POWER ON AUTO-RECORDS mode on / off.**

[ POW ON AUTO REC ]

ON

\*OFF

UP DOWN



## PLAY SETUP



**Step 1.** Press the (MENU) button into the menu mode.

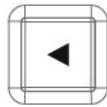

**Step 2.** Press the (DOWN) button select to the **SETUP** menu.



**Step 3.** Press the (ENTER) button into the **SETUP** menu.

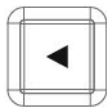
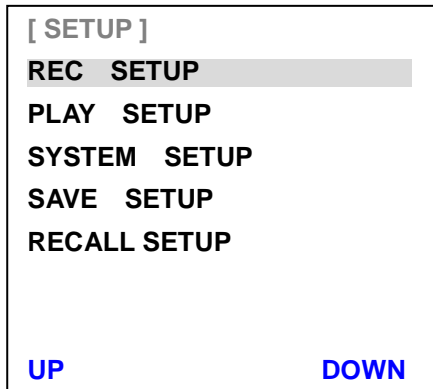

**Step 4.** Press the (UP) button / (DOWN) button to select the **PLAY SETUP** menu.



**Step 5.** Press the (ENTER) button into the **PLAY SETUP** menu.

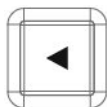
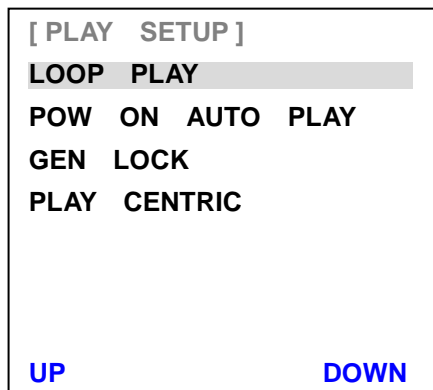

**Step 6.** Press the (UP) button / (DOWN) button to select the **LOOP PLAY / POWER ON AUTO-PLAY / GEN LOCK / PLAY CENTRIC** menu.



**Step 7.** Press the (ENTER) button into the **LOOP PLAY / POWER ON AUTO PLAY / GEN LOCK / PLAY CENTRIC** menu.

**Note:** If LOOP PLAY function is OFF, the clip will not be played when it is played to the end or rewind to the beginning.

**LOOP PLAY** - Setting the LOOP PLAY mode (on / off).

[ LOOP PLAY ]	
ON	
*OFF	
UP	DOWN

**POWER ON AUTO PLAY** - Setting the POWER ON AUTO PLAY mode (on / off).

[ POWER ON AUTO PLAY ]	
ON	
*OFF	
UP	DOWN

**GEN LOCK** - Setting the GEN LOCK mode (on / off).

[ GEN LOCK ]	
ON	
*OFF	
UP	DOWN

**Note:** Genlock is only available in play mode.

**PLAY CENTRIC** - Setting the PLAY CENTRIC mode (bin / CLIP).

[ PLAY CENTRIC ]	
BIN	
*CLIP	
UP	DOWN

CLIP = When LOOP PLAY mode is on, HRS-30 will loop play CLIP file.  
When LOOP PLAY mode is off, HRS-30 will pause at the end of the CLIP.

BIN = When LOOP PLAY mode is on, HRS-30 will play all CLIPs of BIN file until it reaches to the end of last CLIP; it will then loop back to beginning of the CLIP 1.  
When LOOP PLAY mode is off, HRS-30 will pause at the end of the BIN.

## SYSTEM SETUP



**Step 1.** Press the (MENU) button into the menu mode.

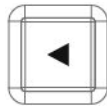

**Step 2.** Press the (DOWN) button select to the **SETUP** menu.



**Step 3.** Press the (ENTER) button into the **SETUP** menu.

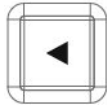
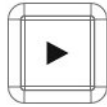

**Step 4.** Press the (UP) button / (DOWN) button select to the **SYSTEM SETUP** menu.

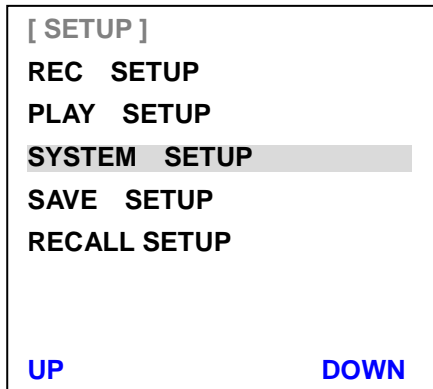

**Step 5.** Press the (ENTER) button into the **SYSTEM SETUP** menu.

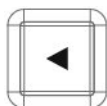
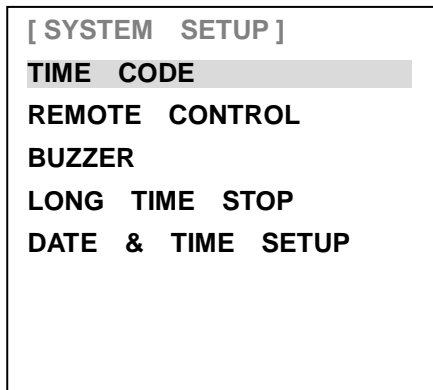

**Step 6.** Press the (UP) button / (DOWN) button to select the **TIMECODE / REMOTE CONTROL / BUZZER / LONG TIME STOP / DATE & TIME SETUP** menu.



**Step 7.** Press the (ENTER) button into the **TIMECODE / REMOTE CONTROL / BUZZER / LONG TIME STOP / DATE & TIME SETUP** menu.

### TIMECODE

Setting the TIME CODE running at INTERNAL RCA RUN / INTERNAL FREE RUN / EXTERNAL TC IN or EXTERNAL SDI TC.

[ TIME CODE ]	
<input checked="" type="radio"/>	INTERNAL REC RUN
<input type="radio"/>	INTERNAL FREE RUN
<input type="radio"/>	EXTERNAL TC IN
<input type="radio"/>	EXTERNAL SDI TC
UP	DOWN

**Note:** INTERNAL FREE RUN time code follows system real time clock.

### REMOTE CONTROL

Setting the REMOTE CONTROL (rear panel RJ-45 connector) function on / off.

[ REMOTE CONTROL ]	
<input checked="" type="radio"/>	DISABLE
<input type="radio"/>	ENABLE
UP	DOWN

**Note:** When this function enable, other button function will disable.

### BUZZER

Setting the BUZZER function on / off.

This buzzer will be activated to alarm if there is an "unrecoverable" defect of HRS-30.



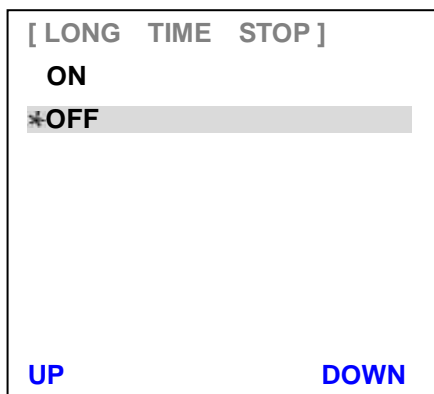

[ BUZZER ]	
<input type="radio"/>	ON
<input checked="" type="radio"/>	OFF
UP	DOWN

## LONG TIME STOP

Setting the HOLD 1 SECONDS TO STOP function on / off.



## DATE & TIME SETUP

Into the **DATE & TIME SETUP** mode, use the  (UP) /  (DOWN) /  (Fwd) /  (Rev) buttons to setting the DATE & TIME.

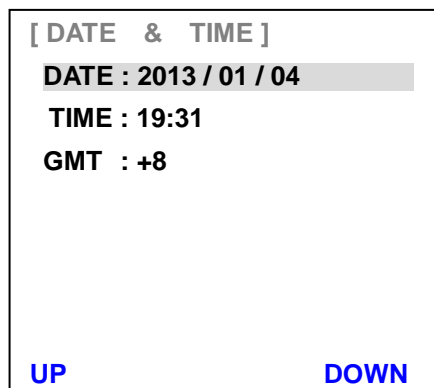

## SAVE SETUP



**Step 1.** Press the (MENU) button into the menu mode.

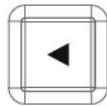

**Step 2.** Press the (DOWN) button into the **SETUP** menu.



**Step 3.** Press the (ENTER) button into the **SETUP** menu.

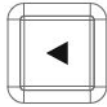
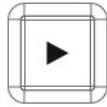

**Step 4.** Press the (UP) button / (DOWN) button select to the **SAVE SETUP** menu.

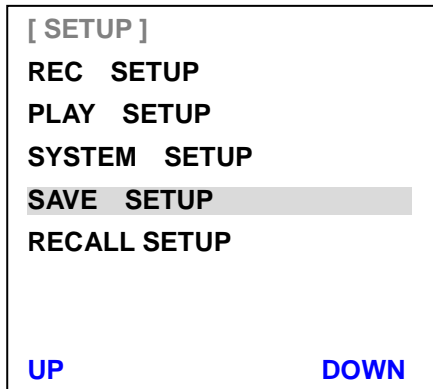

**Step 5.** Press the (ENTER) button into the **SAVE ETUP** menu.

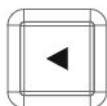
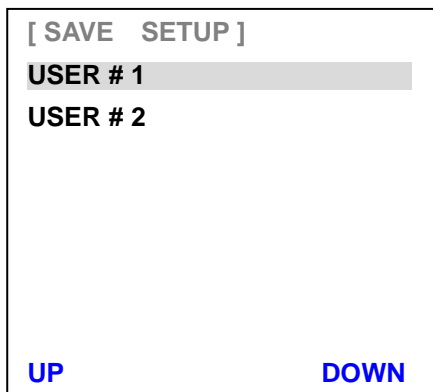

**Step 6.** Press the (UP) button / (DOWN) button to select save the **USER #1** or **USER #2**.



**Step 7.** Press the (ENTER) button to confirm your select.

## RECALL SETUP

**Step 1.** Press the  (MENU) button into the menu mode.

**Step 2.** Press the  (DOWN) button into the **SETUP** menu.

**Step 3.** Press the  (ENTER) button into the **SETUP** menu.

**Step 4.** Press the  (UP) button /  (DOWN) button select to the **RECALL SETUP** menu.

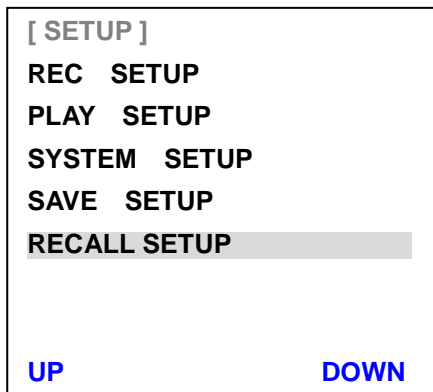

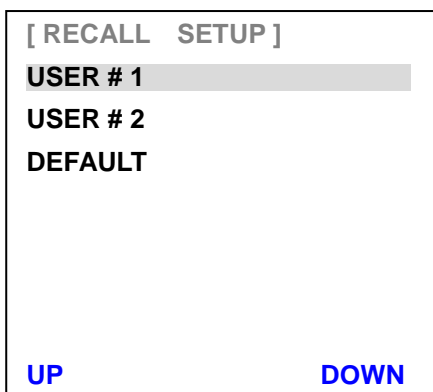

**Step 5.** Press the  (ENTER) button into the **RECALL SETUP** menu.

**Step 6.** Press the  (UP) button /  (DOWN) button to select recall **USER #1 / USER #2** or **FACTORY DEFAULT** file.



**Step 7.** Press the  (ENTER) button to confirm your select.

**Step 8.** Press the  (UP) button /  (DOWN) button to select "**YES**", and then press the  (ENTER) button to confirm your select.

# **STATUS**



**Step 1.** Press the (MENU) button into the menu mode.

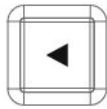
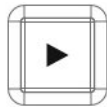

**Step 2.** Press the (UP) button / (DOWN) button select to the **STATUS** menu.

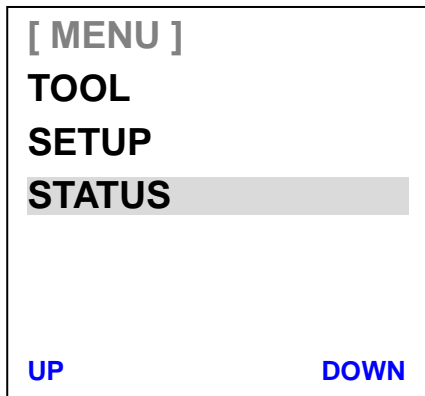

**Step 3.** Press the (ENTER) button into the **STATUS** menu.

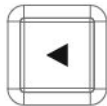

**Step 4.** Press the (UP) button / (DOWN) button to see the **FILE FORMAT / BIN FILE LENGTH / RECORD SETUP / INPUT / TIME CODE / GENLOCK** status.

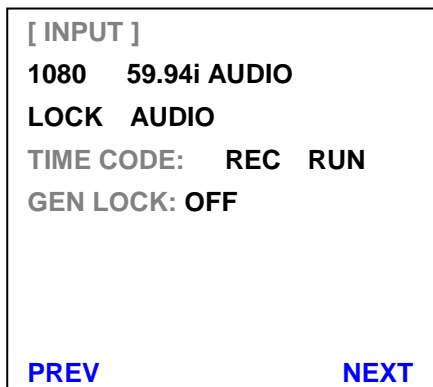
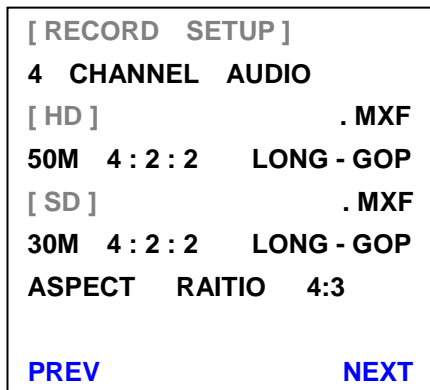
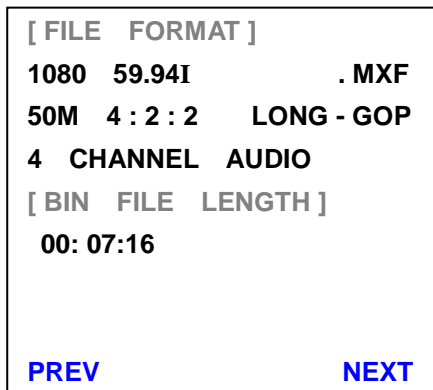



## Assemble 2.5" HDD in Removable Rack

Step 1. Put the 2.5" HDD into the rack.

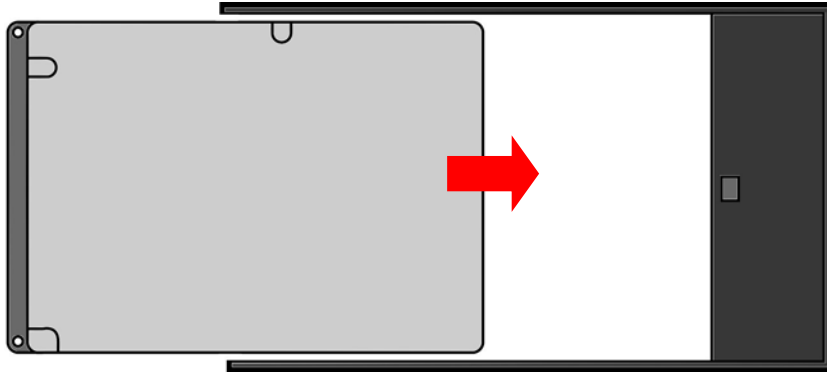

Step 2. Assemble four screws to fasten 2.5" HDD on the rack.

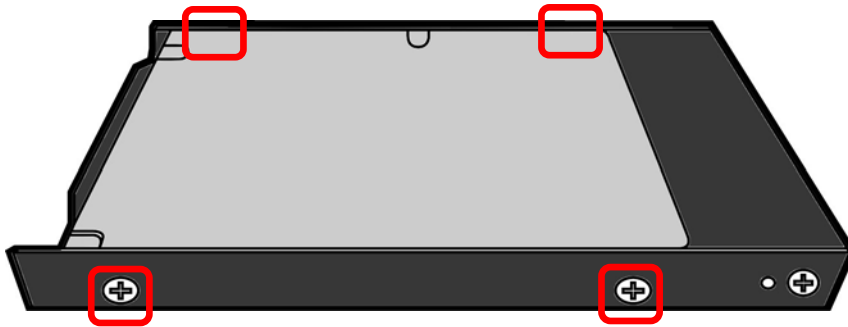

Step 3. Push the button to Left side and then push the rack into HRS-30.

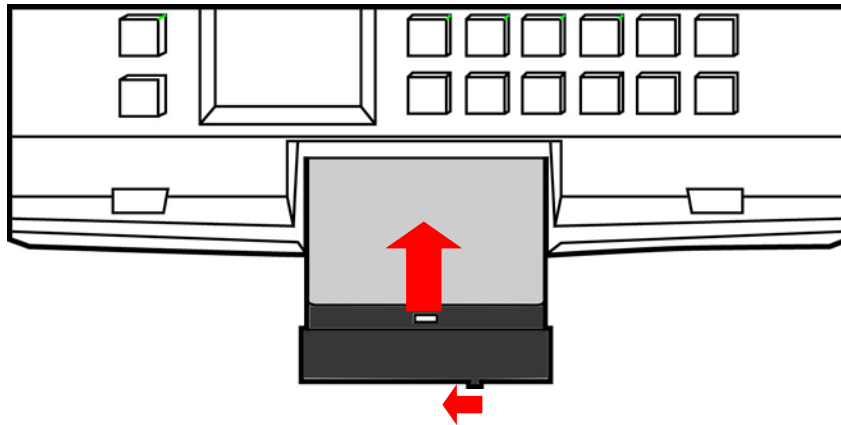

Step 4. Push the button to right side, for lock the rack.

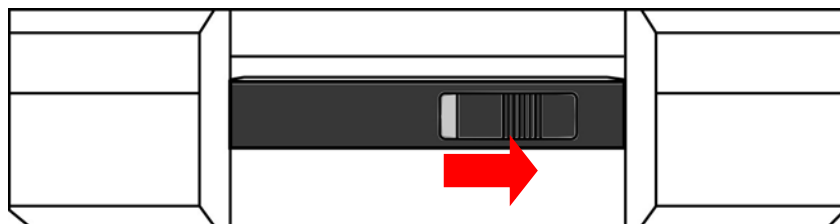

## Connecting the 2.5”HDD to PC

The HDD drive caddy can be pull out and connected to a PC or MAC with the supplied USB cable.

**Step 1.** First turn off the HRS-30.

**Step 2.** Turn the drive caddy lock lever to the right to unlock the HDD drive caddy. Pull out the HDD drive caddy.

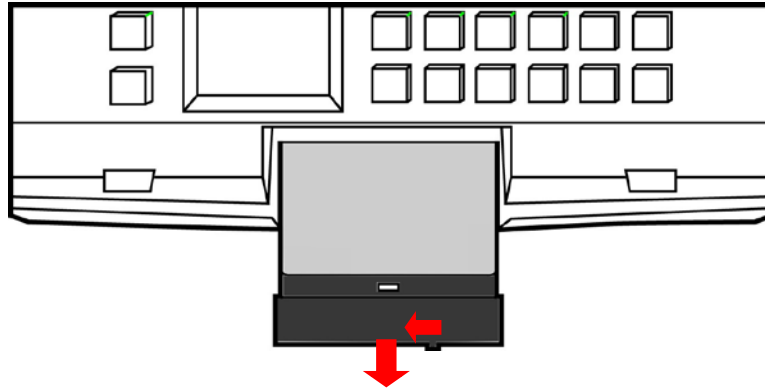

**Step 3.** The HDD drive caddy is fitted with a SATA connector on its rear; this can provide power to the HDD, as well as allow the exchange of data.



**Step 4.** Connect the supplied SATA-USB cable to the HDD drive caddy, and connect the double lead to your PC or Laptop. Please connect two USB to the computer.

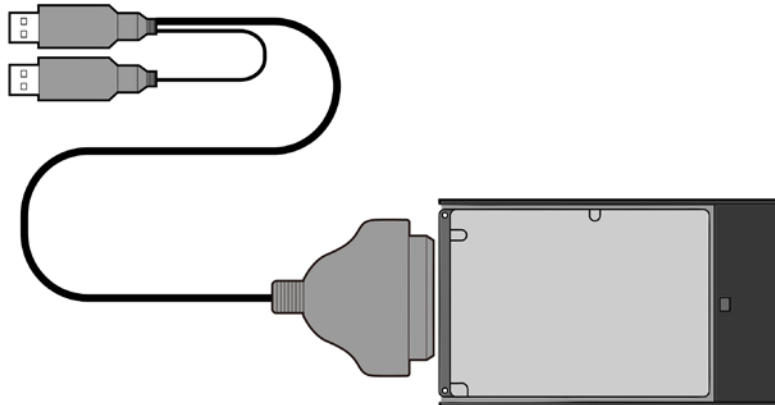

**Step 5.** When connected to a PC a new Local Disk should appear, and the files are available to drag and drop or access directly.

### The HRS-30 system files type:

1. One BIN = 99 CLIP (max).
2. HRS-30 REC over 10 hours will add one CLIP.
3. When you pause / stop REC or REC error, the HRS-30 system will add one CLIP.

## Connecting the 2.5”HDD to MAC

**Step 1.** Connect the supplied SATA-USB cable to the HDD drive caddy, and connect the double lead to your MAC. Please connect two USB to your MAC.

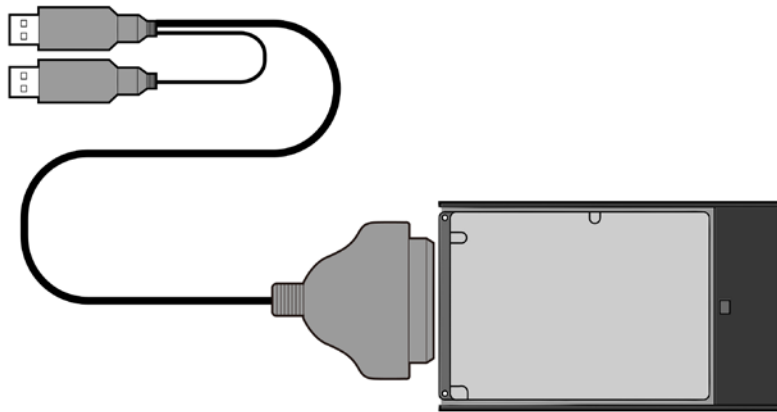

**Step 2.** A Datavideo drive will appear on the desktop.



**Step 3.** If you access the drive you will see the files are available for copying across to a local drive, or direct access.



## Q & A

**Q 1:** What causes the HRS-30 to show “**CLOSE TO FULL**” on the 2” LCD Display Panel?

**Ans:** When HRS-30 HDD recordable time is less than **5 minutes**, the HRS-30 will show “**CLOSE TO FULL**” on Recorder Monitor.

**Q 2:** While the HRS-30 is recording, what sudden power loss cause?

**Ans:** HRS-30 will lose the last 6 seconds of recorded data on the HDD.

**Q 3:** Why “**LONG GOP**” option is not available?

**Ans:** You need to enter the SETUP page, select **TIME LAPSE** option and disable this function; please see page 22 for more details.

**Q 4:** Why play or record cannot be stopped?

**Ans:** You need to enter the SETUP page, select **LONG TIME STOP** option and disable this function; please see page 27 for more details.

**Q 5:** What causes the HRS-30 to show “**UNLOCK AUDIO**” on the 2” LCD Display Panel?

**Ans:** Please check the connection of SDI input source and make sure the signal is normal.

**Q 6:** Why buttons on the recorder panel are not operational when HRS-30 **REMOTE CONTROL** function is enabled?

**Ans:** **REMOTE CONTROL** function and **Recorder Operation** buttons cannot be enabled at the same time.

**Q 7:** What causes the HRS-30 to show “**WRONG MEDIA**” on the 2” LCD Display Panel?

**Ans:** 1. If HDD drive is used for the first time, HRS-30 will show “**WRONG MEDIA**” on the 2” LCD Display Panel for remind you to format HDD, so please format the HDD.

2. If you taken a HDD from HRS-30 and inserted to another HRS-30, HRS-30 will show “**WRONG MEDIA**” on the 2” LCD Display Panel for remind you to format HDD, so please format the HDD.

**Q 8:** What causes the HRS-30 to show “**FMT MISMATCH**” on the 2” LCD Display Panel?

**Ans:** **To record** different **CLIPs** in the same **BIN** folder, the files must be set to the same format (video source format, bit rate setting, audio channel setting and etc).

**Q 9:** What causes the SD-SDI no time code output?

**Ans:** HRS-30 not supports SD-SDI time code to output.

## HRS-30 Error Codes

XX
01: Interface FPGA no response when boot
02: Recorder FW no response when boot
03: Codec FW no response when boot
04: Main board and Controller connect error.
10: Recorder FW wrong stop by itself while recording
11: Recorder FW wrong stop by itself while playing
12: Recorder FW no response to the command from HOST when recording or playback
20: Codec Reset Timeout
21: Codec Sync errors or State Conversion Error when playing
23: Codec TRIS Error

YY
78: ATA command FLUSH_CACHE timeout
7A: ATA command SETUP_DMA_MODE timeout
7C: receive status error after sending ATA command, then retry sending ATA command 3 times and still receive status error
7F: DISK keep busy more than 3 seconds after sending ATA command
8E: CLIP code errors found during the initial recording (not within the range of 1-99)
8F: BIN code errors found during the initial recording (not within the range of 1-99)
C3: At the beginning of recording, there is an error when reading the file system data
C6: Recorder FPGA no returns continuing 3 seconds while recording
C7: Frame Table Overflow when recording
CB: Memory is incorrectly overwritten
BF: RECORDER FPGA stop on their own when playing
BB: RECORDER FW hard disk data read errors when playing

# HRS-30 RS-232 Control Command

## 1. Interface Overview

- Standard transmission rate on the interface bus is 38400 bits per seconds (bps)
- 1 Start bit + 8 Data bits + 1 Parity bit + 1 Stop bit. Odd Parity

## 2. Command Table

Command	Name	Response Data
	<b>Common Transport Control</b>	
20h, 00h, 20h	Stop	10h, 01h, 11h
20h, 01h, 21h	Play	10h, 01h, 11h
20h, 02h, 22h	Record	10h, 01h, 11h
21h, 02h, 00h, 23h	Record Pause	10h, 01h, 11h
	<b>Common Trick Play</b>	
21h, 11h, 00h, 32h	Play Pause	10h, 01h, 11h
20h, 10h, 30h	Fast Forward	10h, 01h, 11h
21h, 13h, nn, csum	Shuttle Forward	10h, 01h, 11h
20h, 15h, 35h	Jump Forward	10h, 01h, 11h
20h, 20h, 40h	Fast Rewind	10h, 01h, 11h
21h, 23h, nn, csum	Shuttle Reverse	10h, 01h, 11h
20h, 25h, 45h	Jump Reverse	10h, 01h, 11h
	<b>Vender Unique Control</b>	
01h, F0h, nn, csum	Select Bin(1~99)	10h, 01h, 11h
00h, F1h, F1h	Next Bin	10h, 01h, 11h
00h, F2h, F2h	Previous Bin	10h, 01h, 11h
	<b>Common System Control</b>	
00h, 11h, 11h	Device Type Request	12h, 11h, 00h, 01h, 24h
	<b>Vender Unique Control (External)</b>	
02h, F3h, 01h, nn, csum	Select Bin & Delete(1~99)	10h, 01h, 11h
02h, F3h, 05h, xx, csum	HD Rec Format (I-only/LGOP)	10h, 01h, 11h
02h, F3h, 05h, 00h, FAh	HD Long-GOP	10h, 01h, 11h
02h, F3h, 05h, 01h, FBh	HD I frame only	10h, 01h, 11h
02h, F3h, 06h, xx, csum	Bit Rate Select (HD)	10h, 01h, 11h
	LGOP:10/25/35/50/65/120	10h, 01h, 11h
	I-only:100/125	10h, 01h, 11h
02h, F3h, 07h, xx, csum	Bit Rate Select (SD)	10h, 01h, 11h
	LGOP:8/15/30/50	10h, 01h, 11h
	I-only:25/50	10h, 01h, 11h
02h, F3h, 09h, xx, csum	SD Aspect 4x3 or 16x9	10h, 01h, 11h
02h, F3h, 09h, 00h, FEh	SD Aspect :4x3	10h, 01h, 11h
02h, F3h, 09h, 01h, FFh	SD Aspect :16x9	10h, 01h, 11h
02h, F3h, 0Ah, xx, csum	SD Rec Format (I-only/LGOP)	10h, 01h, 11h
02h, F3h, 0Ah, 00h, FFh	SD Long-GOP	10h, 01h, 11h
02h, F3h, 0Ah, 01h, 00h	SD I frame only	10h, 01h, 11h
* 02h, F5h, 04, xx, csum	Rec SD File type	10h, 01h, 11h
* 02h, F5h, 05, xx, csum	Rec HD File type	10h, 01h, 11h
* 02h, F5h, 03, xx, csum	TimeLapse Enable	10h, 01h, 11h
* 02h, F5h, 06, xx, csum	Power On Auto Record	10h, 01h, 11h
02h, F5h, 08h, 00h, FFh	Disable Loop Play	10h, 01h, 11h
02h, F5h, 08h, 01h, 00h	Enable Loop Play	10h, 01h, 11h
* 02h, F5h, 12h, xx, csum	Power On Auto PLAY	10h, 01h, 11h
* 04h, F5h, 15h, [3 bytes], csum	Time Lapse Control	10h, 01h, 11h
* 08h, F5h, 17h, [7 bytes], csum	Set Real Time Clock	10h, 01h, 11h
* 02h, F5h, 22h, xx, csum	Gen Lock control	10h, 01h, 11h
* 02h, F5h, 23h, xx, csum	Buzzer Control	10h, 01h, 11h
* 02h, F5h, 24h, xx, csum	Audio Channel number	10h, 01h, 11h
	<b>Vender Unique System Control</b>	
21h, F1h, 00h, 12h	Next (Right key)	10h, 01h, 11h
21h, F1h, 01h, 13h	Next Bin	10h, 01h, 11h
21h, F1h, 02h, 14h	Next Clip	10h, 01h, 11h
21h, F2h, 00h, 13h	Previous (Left Key)	10h, 01h, 11h
21h, F2h, 01h, 14h	Previous Bin	10h, 01h, 11h
21h, F2h, 02h, 15h	Previous Clip	10h, 01h, 11h

Command	Name	Response Data
	<b>Vender Unique System Commands (External)</b>	
01h, F6h, 00, F7h	Make Media File (Unlock Media)	10h, 01h, 11h
01h, F6h, 01, F8h	Empty Current Bin	10h, 01h, 11h
01h, F6h, 02, F9h	Empty All (Format Media)	10h, 01h, 11h
	<b>Sense Control</b>	
61h, 0Ch, 04h, 71h	Time code Sense	74h, 00h, TC(3:0), csum
61h, 20h, 0Fh, 90h	Status Sense	7Fh, 20h, [15 bytes], csum
61h, 20h, xnh, csum	Variable Status Sense	7nh, 20h, [n bytes], csum
	<b>Vender Unique Sense Control</b>	
62h, F2h, 05h, 00h, 59h	Firmware Revision Sense (Recorder)	79h, F2h, 05h, 00h, [7 bytes], csum
62h, F2h, 05h, 01h, 5Ah	Firmware Revision Sense (Host)	79h, F2h, 05h, 01h, [7 bytes], csum
62h, F2h, 05h, 02h, 5Bh	Firmware Revision Sense (CODEC)	79h, F2h, 05h, 02h, [7 bytes], csum

#### 04h, F5h, 15h, [3 bytes] : Time Lapse Control

04	F5	15	Frame	Sec[1]	Sec[0]	csum
----	----	----	-------	--------	--------	------

#### 08h, F5h, 17h, [7 bytes] : Set Real Time Clock

08	F5	17	Year[1]	Year[0]	Month	Day	Hour	Min	Sec	GMT	csum
----	----	----	---------	---------	-------	-----	------	-----	-----	-----	------

### 3. Return Data

#### 10h 01h : ACK

10h	01h	csum
-----	-----	------

When a command from the CONTROLLER is received normally, the DEVICE returns this command as acknowledgment

#### 11h 12h : NAK

11h	12h	Data byte	csum
-----	-----	-----------	------

When a communication error is detected or an undefined COMMAND is received, the DEVICE returns this command as not-acknowledgment. Bit-7 to Bit-0 of Data byte will be set in accordance with the contents.

[Data byte]

Bit-7	Bit-6	Bit-5	Bit-4	Bit-3	Bit-2	Bit-1	Bit-0
0	0		Parity Error	INHIBIT	CHECKSUM ERROR	0	UNDEFINED COMMAND

#### 12h 11h : DEVICE TYTPE

12h	11h	Device byte1	Device byte2	csum
-----	-----	--------------	--------------	------

The“00h, 11h, 11h : DEVICE TYPE REQUEST” command is used for asking the specifications of the HRS-30 used as DEVICE. When the DEVICE receives this command, it attaches 2-bytes specification data to “12h 11h : DEVICE TYPE” and sends the information to the CONTROLLER.

HRS-30: 12h , 11h, 00h, 01h, csum,

#### 4. Trick Play

21h 13h nn csum : Shuttle Forward

21h 23h nn csum : Shuttle Reverse

nn	speed	Command Forward	Command Reverse
62h	12X	21h 13h 62h 96h	21h 23h 62h A6h
5E h	9X	21h 13h 5Eh 92h	21h 23h 5Eh A2h
58 h	6X	21h 13h 58h 8Ch	21h 23h 58h 9Ch
4F h	3X	21h 13h 4Fh 83h	21h 23h 4Fh 93h
40h	1X	21h 13h 40h 74h	21h 23h 40h 84h

36h	1/2X	21h 13h 36h 6Ah	21h 23h 36h 7Ah
30 h	1/3X	21h 13h 30h 64h	21h 23h 30h 74h
27h	1/6X	21h 13h 27h 5Bh	21h 23h 27h 6Bh
21h	1/9X	21h 13h 21h 55h	21h 23h 21h 65h
1Dh	1/12X	21h 13h 1Dh 51h	21h 23h 1Dh 51h

Note: 1/2X is for I-frame only.

#### 5. Vender Unique System Control

21h, F1h, 02h, 14h : Next Clip

21h, F2h, 02h, 15h : Previous Clip

Note: Only can do clip-change at play-pause

#### 6. Firmware Revision Sense Data[7bytes]

##### Firmware Revision Sense (Recorder)

Byte[0]: ROM  
Byte [1]: FW Major  
Byte [2]: FW Minor  
Byte [3]: File System  
Byte [4]: FPGA  
Byte [5]: RBF  
Byte [6]: ESP

##### Firmware Revision Sense (Host)

Byte [0]: FW Major  
Byte [1]: FW Minor  
Byte [2]: Control CMD Major  
Byte [3]: Control CMD Minor  
Byte [4]: Bootloader Minor  
Byte [5]: 0x00  
Byte [6]: 0x00

##### Firmware Revision Sense (Codec)

Byte [0]: Codec Bootloader Major  
Byte [1]: Codec Bootloader Minor  
Byte [2]: Codec Host Major  
Byte [3]: Codec Host Minor  
Byte [4]: Codec Major  
Byte [5]: Codec Minor  
Byte [6]: 0x00



## 7. Variable Status Sense

61h, 20 h, xnh, csum

The return-byte is variable for Status Sense.

The 3<sup>rd</sup> byte of command:

MSD (Bit7~4, x): Indicates the initial byte index of the to be returned.

LSD (Bit3~0, n): Indicates the number of data bytes to be returned.

## 8. Status Sense Control Command Response Bytes

Mode Status: 0=Play Mode

Status Byte	Bit 7	Bit 6	Bit 5	Bit 4	Bit 3	Bit 2	Bit 1	Bit 0
0	Busy	0	Cartridge Out	0	0	Wrong Media	0	Local enable
1	0	0	Stop		Rewind	Fast Forward	Record	Play
2	0	0	0		0	Reverse	Still (Pause)	0
3	0	0	0	0	0	0	Video in	0
4	1	0	0	0	1	0	0	0
5	0	0		0	0	0	0	0
6	0	0	0	0	0	0	0	0
7	0	0	0	0	0	0	0	0
8	0	0	Near End of Disk (panic mode)	End of disk	0	0	0	1
9	0	0	0	0	0	0	0	0
10	BIN7	BIN6	BIN5	BIN4	BIN3	BIN2	BIN1	BIN0
11	File Length byte 0	FL0	FL0	FL0	FL0	FL0	FL0	FL0
12	Length Byte 1	FL1	FL1	FL1	FL1	FL1	FL1	FL1
13	Length Byte 2	FL2	FL2	FL2	FL2	FL2	FL2	FL2
14	Length Byte 3	FL3	FL3	FL3	FL3	FL3	FL3	FL3

# Example HRS-30 Set Up

Type A:

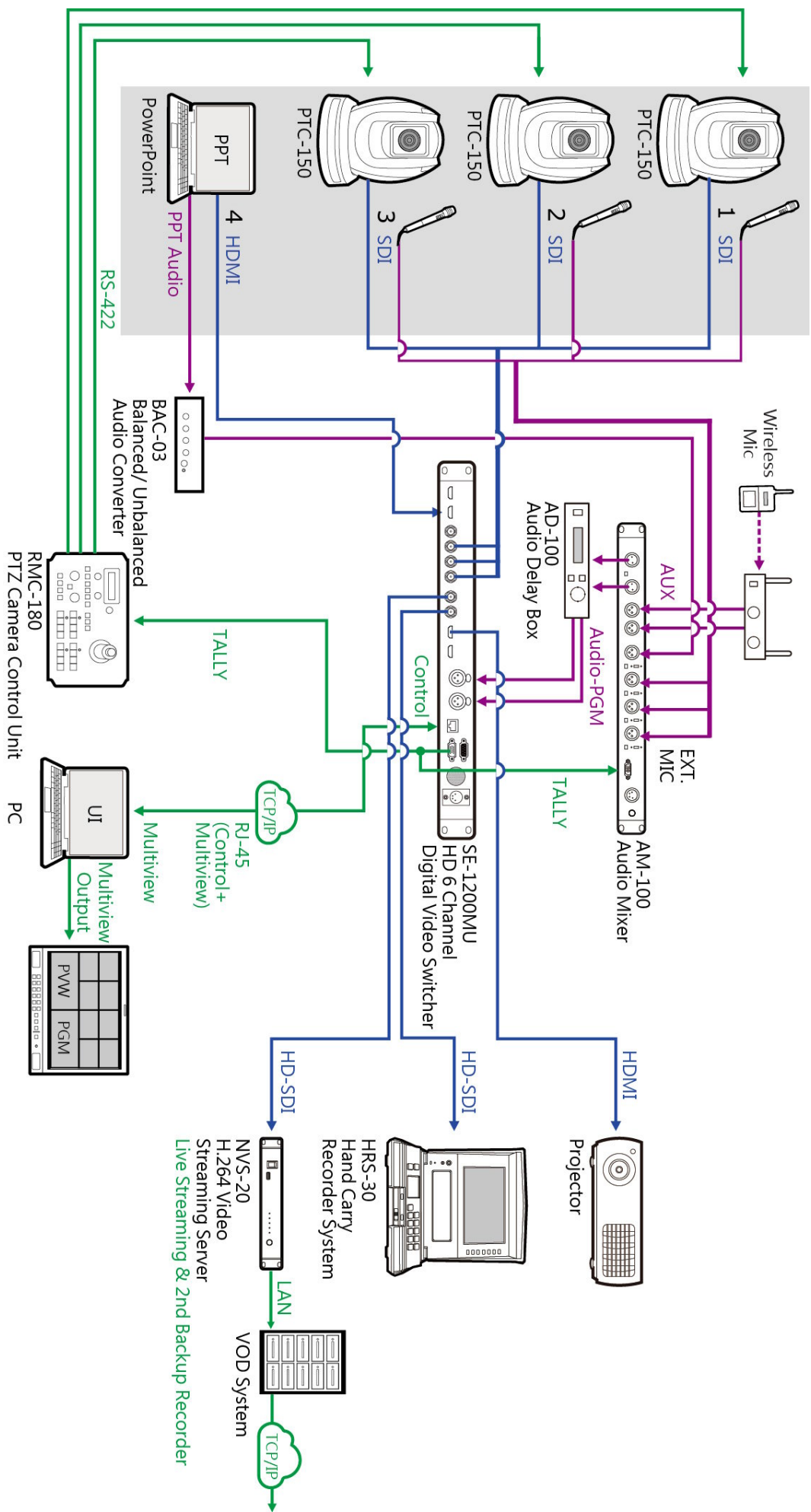

Type B:

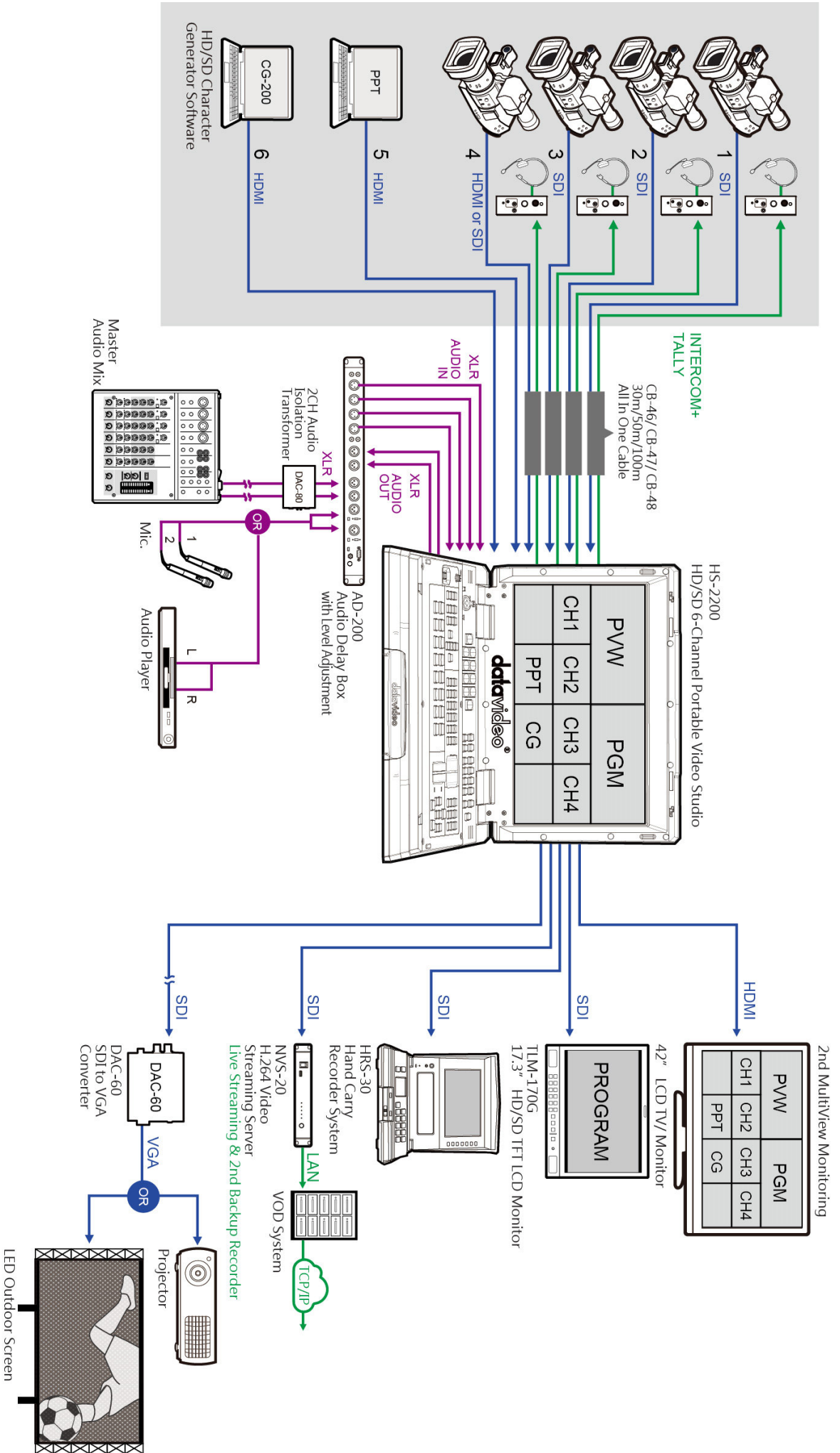

## RJ-45 Pin Define

This pin define is use for RJ-45 connect to RS-232 connector.

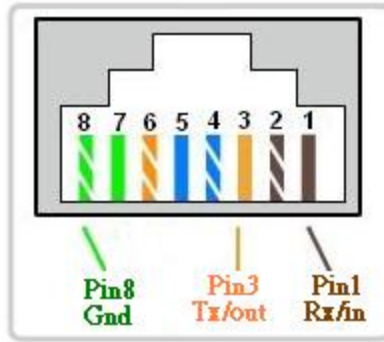

## Dimensions

All measurements in millimetres (mm).

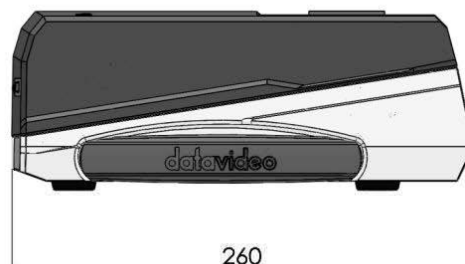
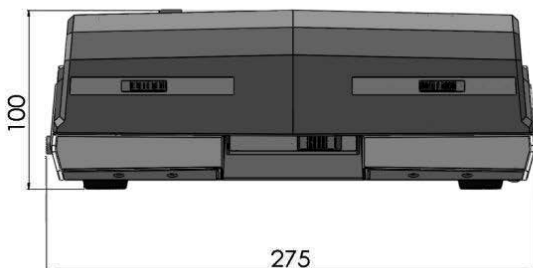
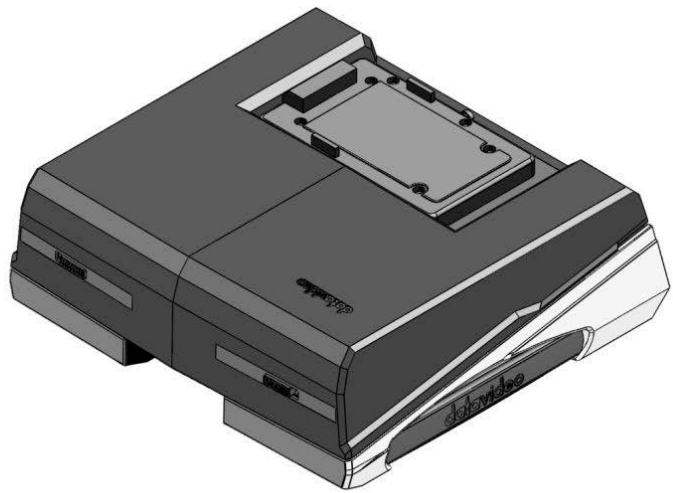
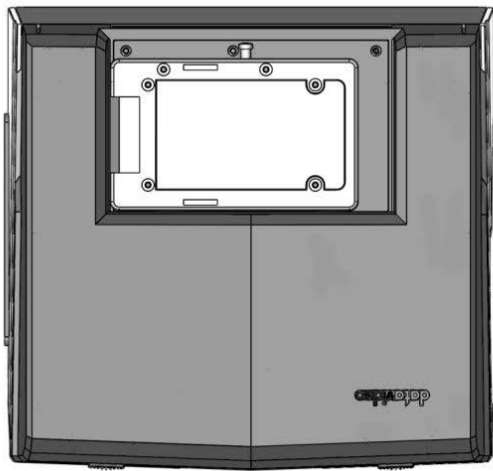

## Specifications

<b>General Specification</b>	
<b>Video Standard</b>	HD/SD
<b>Video Format</b>	1080P 23.97/24Hz 1080i 50/59.94/60Hz 720P 50/59.94/60Hz 480i / 576i
<b>Storage Medium</b>	2.5" HDD / SSD, Max capacity 1T GB * Note: SSD is recommended
<b>Estimated Record Time (min per 10GB)</b>	SD:22(50Mbps) ~75(8Mbps) HD: 10 (125Mbps)~68 (10Mbps)
<b>How to retrieve Recorded Content</b>	Removable HDD/SSD, transfer data via USB 3.0
<b>Recorded File Format</b>	MXF OP1A, MOV
<b>Video Recording Bit Rate / Color Sampling</b>	<p><b>MPEG2 Long GOP HD:</b></p> <ol style="list-style-type: none"> <li>1. 10Mbps 4:2:0 1440x1080/1280x720,</li> <li>2. 25Mbps 4:2:0 1440x1080/1280x720,</li> <li>3. 35Mbps 4:2:2 1920x1080/1280x720,</li> <li>4. 50Mbps 4:2:2 1920x1080/1280x720,</li> <li>5. 65Mbps 4:2:2 1920x1080/1280x720,</li> <li>6. 120Mbps 4:2:2 1920x1080/1280x720,</li> </ol> <p><b>MPEG2 Long GOP SD</b></p> <ol style="list-style-type: none"> <li>1. 8Mbps 4:2:0 720x480/720x576</li> <li>2. 15Mbps 4:2:2 720x480/720x576</li> <li>3. 30Mbps 4:2:2 720x480/720x576</li> <li>4. 50Mbps 4:2:2 720x480/720x576</li> </ol> <p><b>MPEG2 I-Frame Only HD</b></p> <ol style="list-style-type: none"> <li>1. 100Mbps 4:2:2 1920x1080/1280x720</li> <li>2. 125Mbps 4:2:2 1920x1080/1280x720</li> </ol> <p><b>MPEG2 I-Frame Only SD</b></p> <ol style="list-style-type: none"> <li>1. 25Mbps 4:2:2 720x480/720x576</li> <li>2. 50Mbps 4:2:2 720x480/720x576</li> </ol>
<b>Audio Recording Format</b>	Uncompressed PCM
<b>Time Code</b>	Yes
<b>External Sync/Genlock</b>	Yes, Black Burst & Tri-level w/loop thru
<b>Power Failure protection</b>	Content saved up to last second before power failure

<b>Panel Specification</b>	
<b>Screen size</b>	10.1"
<b>Resolution</b>	1280 (H) × 800 (V)
<b>Dot pitch</b>	0.0565 (W) × 0.1695 (H) mm
<b>Active Area</b>	216.96 (W) × 135.60 (H) mm
<b>Interface</b>	
<b>Support Video Input Signal</b>	1 x SDI
<b>Monitoring/ Playback output</b>	1 x SDI(input loop thru) 1 x HDMI ; 1 x SDI (Out)
<b>Analog Audio Input</b>	N/A
<b>Audio Output</b>	1 x 3.5mm jack for external speaker Speakers 2 x 3W Earphone : 3.5mm standard interface
<b>Embedded Audio</b>	SDI Input / Output (8CH ) HDMI Output (8CH)
<b>Time Code</b>	1 x Input (BNC) 1 x Output (BNC)
<b>Sync Reference</b>	1 x Input (BNC) 1 x Output (BNC)
<b>Phone Charger and Light</b>	4 x USB
<b>F/W Upgrade</b>	1 x USB
<b>Power</b>	- 1 x DC In 12V - External Battery (V-Mount / anton bauer): 14.4V  * Note: does not support 7.2V battery
<b>Power Switch</b>	- Main power switch on the rear On: system on / Off: system off  - Monitor power switch: On: monitor on / Off: monitor off









## Service & Support

It is our goal to make owning and using Datavideo products a satisfying experience. Our support staff is available to assist you to set up and operate your system. Contact your local office for specific support requests. Plus, please visit [www.datavideo.com](http://www.datavideo.com) to access our FAQ section.

**China Shanghai**  
Datavideo Technologies China Co  
601, Building 10, No. 1228,  
Rd. Jiangchang,  
Jingan District, Shanghai  
Tel: +86 21-5603 6599  
Fax: +86 21-5603 6770  
E-mail: [service@datavideo.cn](mailto:service@datavideo.cn)

**China Beijing**  
Datavideo Technologies China Co  
No. 812, Building B, Wankai Center,  
No. 316, Wan Feng Road, Fengtai District,  
Beijing, China  
Tel: +86 10-8586 9034  
Fax: +86 10-8586 9074  
E-mail: [service@datavideo.cn](mailto:service@datavideo.cn)

**China Chengdu**  
Datavideo Technologies China Co  
B-823, Meinian square, No. 1388,  
Middle of Tianfu Avenue, Gaoxin District,  
Chengdu, Sichuan  
Tel: +86 28-8613 7786  
Fax: +86 28-8513 6486  
E-mail: [service@datavideo.cn](mailto:service@datavideo.cn)

**China Fuzhou**  
Datavideo Technologies China Co  
A1-2318-19 Room, No. 8, Aojiang Road,  
Taijiang District, Fuzhou, Fujian, China  
Tel: 0591-83211756 · 0591-83210187  
Fax: 0591-83211262  
E-mail: [service@datavideo.cn](mailto:service@datavideo.cn)

**China Jinan**  
Datavideo Technologies China Co  
902, No. 1 business building,  
Xiangtai Square, No. 129,  
Yingxiongshan Road, Shizhong District,  
Jinan City, Shandong Province, China  
Tel: +86 531-8607 8813  
E-mail: [service@datavideo.cn](mailto:service@datavideo.cn)

**Hong Kong**  
Datavideo Hong Kong Ltd  
G/F., 26 Cross Lane  
Wanchai, Hong Kong  
Tel: +852-2833-1981  
Fax: +852-2833-9916  
E-mail: [info@datavideo.com.hk](mailto:info@datavideo.com.hk)

**India Noida**  
Datavideo India Noida  
A-132, Sec-63, Noida-201307,  
India  
Tel: +91-0120-2427337  
Fax: +91-0120-2427338  
E-mail: [sales@datavideo.in](mailto:sales@datavideo.in)

**India Kochi**  
Datavideo India Kochi  
2nd Floor- North Wing, Govardhan Building,  
Opp. NCC Group Headquarters, Chittoor Road,  
Cochin- 682035  
Tel: +91 4844-025336  
Fax: +91 4844-047696  
E-mail: [sales@datavideo.in](mailto:sales@datavideo.in)

**Netherlands**  
Datavideo Technologies Europe BV  
Floridadreef 106  
3565 AM Utrecht,  
The Netherlands  
Tel: +31-30-261-96-56  
Fax: +31-30-261-96-57  
E-mail: [info@datavideo.nl](mailto:info@datavideo.nl)

**Singapore**  
Datavideo Visual Technology(S) Pte Ltd  
No. 178 Paya Lebar Road #06-07  
Singapore 409030  
Tel: +65-6749 6866  
Fax: +65-6749 3266  
E-mail: [info@datavideovirtualset.com](mailto:info@datavideovirtualset.com)

**Singapore**  
Datavideo Technologies (S) PTE Ltd  
No. 178 Paya Lebar Road #06-03  
Singapore 409030  
Tel: +65-6749 6866  
Fax: +65-6749 3266  
E-mail: [sales@datavideo.sg](mailto:sales@datavideo.sg)

**Taiwan**  
Datavideo Technologies Co. Ltd  
10F. No. 176, Jian 1st Rd., Chung Ho  
District, New Taipei City 235, Taiwan  
Tel: +886-2-8227-2888  
Fax: +886-2-8227-2777  
E-mail: [service@datavideo.com.tw](mailto:service@datavideo.com.tw)

**United States**  
Datavideo Corporation  
7048 Elmer Avenue.  
Whittier, CA 90602,  
U.S.A.  
Tel: +1-562-696 2324  
Fax: +1-562-698 6930  
E-mail: [sales@datavideo.com](mailto:sales@datavideo.com)

**United Kingdom**  
Datavideo UK Limited  
Brookfield House, Brookfield Industrial  
Estate, Peakdale Road, Glossop,  
Derbyshire, SK13 6LQ  
Tel: +44-1457 851 000  
Fax: +44-1457 850 964  
E-mail: [sales@datavideo.co.uk](mailto:sales@datavideo.co.uk)

**France**  
Datavideo France s.a.r.l.  
Cit  Descartes 1, rue Albert Einstein  
Champs sur Marne 774477 –  
Marne la Vall e cedex 2  
Tel: +33-1-60370246  
Fax: +33-1-60376732  
E-mail: [info@datavideo.fr](mailto:info@datavideo.fr)



Please visit our website for latest manual update.  
[www.datavideo.com/product/HRS-30](http://www.datavideo.com/product/HRS-30)

**datavideo**  
[www.datavideo.com](http://www.datavideo.com)